

CATALOGO PARTI RICAMBIO

CATALOGUE DES PIECES DE RECHANGE

SPARE PARTS CATALOGUE

MV 350 B

TURISMO



CATALOGO PARTI RICAMBIO
CATALOGUE DES PIECES DE RECHANGE
SPARE PARTS CATALOGUE

MV 350
TURISMO

MECCANICA VERGHERA

STABILIMENTI: CASCINA COSTA - VERGHERA (GALLARATE)

TELEFONO 20.478 GALLARATE - TELEGRAMMI: EMMEVI (GALLARATE)

STABILIMENTI: CASCINA COSTA-VERGHERA (GALLARATE) (ITALY)

IMPORTANTE

Le ordinazioni per ciascun pezzo richiesto devono essere redatte su apposito modulo con data, nome e indirizzo esatto del richiedente.

Dette ordinazioni devono essere indirizzate a:
MECCANICA VERGHERA S.p.A.
21013 GALLARATE(Varese)

Telegrammi:
EMMEVI- GALLARATE

Telex:
31057 AGUSTA

Per ciascuna qualità dei pezzi desiderati, ogni ordinazione deve contenere le seguenti indicazioni:

- 1° - Il numero di ordinazione (II Colonna)
- 2° - La prima parola della denominazione (III colonna) con eventuale indicazione di misura.
- 3° - Quantità pezzi richiesti (IV colonna)

Esempio di ordinazione per lettera:

Favorite al ns. indirizzo i seguenti pezzi di ricambio:
161 70 126 4 00 Carter 1
000 1354 01 3 3 Vite TE
M6x14 10
179 06 010 0 00 Pignone 3

Esempio ordinazione telegrafica:

EMMEVI - GALLARATE
Spedite: 16170126400 - 1
00013540133 - 10
17906010000 - 3

NOTE IMPORTANTE

Les commandes de pièces de rechange doivent nous être adressées sur des formulaires dans lesquels devront être clairement écrits le nom et l'adresse exacts du client.

Les commandes devront être adressées à:
MECCANICA VERGHERA S.p.A.
21013 - GALLARATE(Varese)Italie

Adresse télégraphique:EMMEVI-GALLARATE

Telex:
31057 AGUSTA.

Dans chaque commande on devra préciser, pour chaque pièce désirée:

- 1° - Numero de commande (IIeme colonne)
- 2° - Le premier mot de la dénomination de la pièce avec l'indication éventuelle de la mesure (IIIeme colonne)
- 3° - Quantité des pièces commandées (IVeme colonne)

Exemple de commande par lettre: Veuillez nous envoyer les pièces suivantes:

161 70 126 4 00 Carter 1
000 1354 01 3 3 Vis TE M6x14 10
179 06 010 0 00 Pignon 3

Exemple de commande par telegramme

Envoyez: EMMEVI - GALLARATE

16170126400 - 1
00013540133 - 10
17906010000 - 3

IMPORTANT

The orders for each requested item must be made by appropriate form with date, complete name and address of the buyer.

These orders must be forwarded to:

MECCANICA VERGHERA S.p.A -21013
GALLARATE (Varese) Italy

Cables:
EMMEVI - GALLARATE

Telex: 31057 AGUSTA

For each type of item requested the order must be complete with the following indications:

- 1° - Purchase number (II column)
- 2° - First word of the nomenclature (III column) with indication
- 3° - Quantity of the items requested (IV column)

Example of ordered placed by letter:

Please forward to our address the following spare parts:

161 70 126 4 00 Case 1
000 1354 01 3 3 Screw, dia
M6x14 10
179 06 010 0 00 Pinion 3

Example of order placed by cable:

EMMEVI - GALLARATE

Please send:

16170126400 - 1
00013540133 - 10
17906010000 - 3

INDICE

TABLE DES MATIERES

INDEX

TAB. N°	INDICE	TABLE DES MATIERES	INDEX
1	CARTER-POMPA OLIO	CARTER-POMPE HUILE	CASE GROUP-OIL PUMP
2	BIELLA-PISTONE	BIELLE-PISTON	CONN. ROD-PISTON
3	TESTA-CARBURATORE	CULASSE-CARBURATEUR	HEAD-CARBURATOR
4	FRIZIONE-ALBERO PRIMARIO	EMBRAYAGE-ARBRE PRIM.	CLUTCH-DRIVE SHAFT
5	ALBERO SEC.-AVVIAMENTO	ARBRE SEC.-DEMARRAGE	DRIVEN SHAFT-STARTER
6	SELETTORE	SELECTEUR	SELECTOR
7	TELAIO-FORCELLONE-AMMORT.	CADRE-FOURCHE-AMMORTISSEUR	FRAME-READ FORKS
8	PARAFANGHI-SERBATOIO SELLA-SILENZIATORE	GARDE BOUE-RESERVOIR SELLE-SILENCIEUX	MUD GUARD-TANK SADDLE-SILENCERS
9	FORCELLA TELESCOPICA	FOURCHE TELESCOPIQUE	TELESCOPIC FORK GROUP
10	MANUBRIO	GUIDON	HANDLEBAR
11	MOZZO ANTERIORE	MOYEAU AV.	FRONT HUB GROUP
12	MOZZO POSTERIORE	MOYEAU AR.	REAR HUB GROUP
13	RUOTE E PNEUMATICI	ROUES ET PNEUMATIQUES	TYRES AND TUBES GROUP
14	APPARECCHIATURE ELETTRICHE	INSTALLATION ELECTRIQUE	ELECT. INSTALLATION GROUP
15	VARIE	VARIAS	MISCELLANEOUS

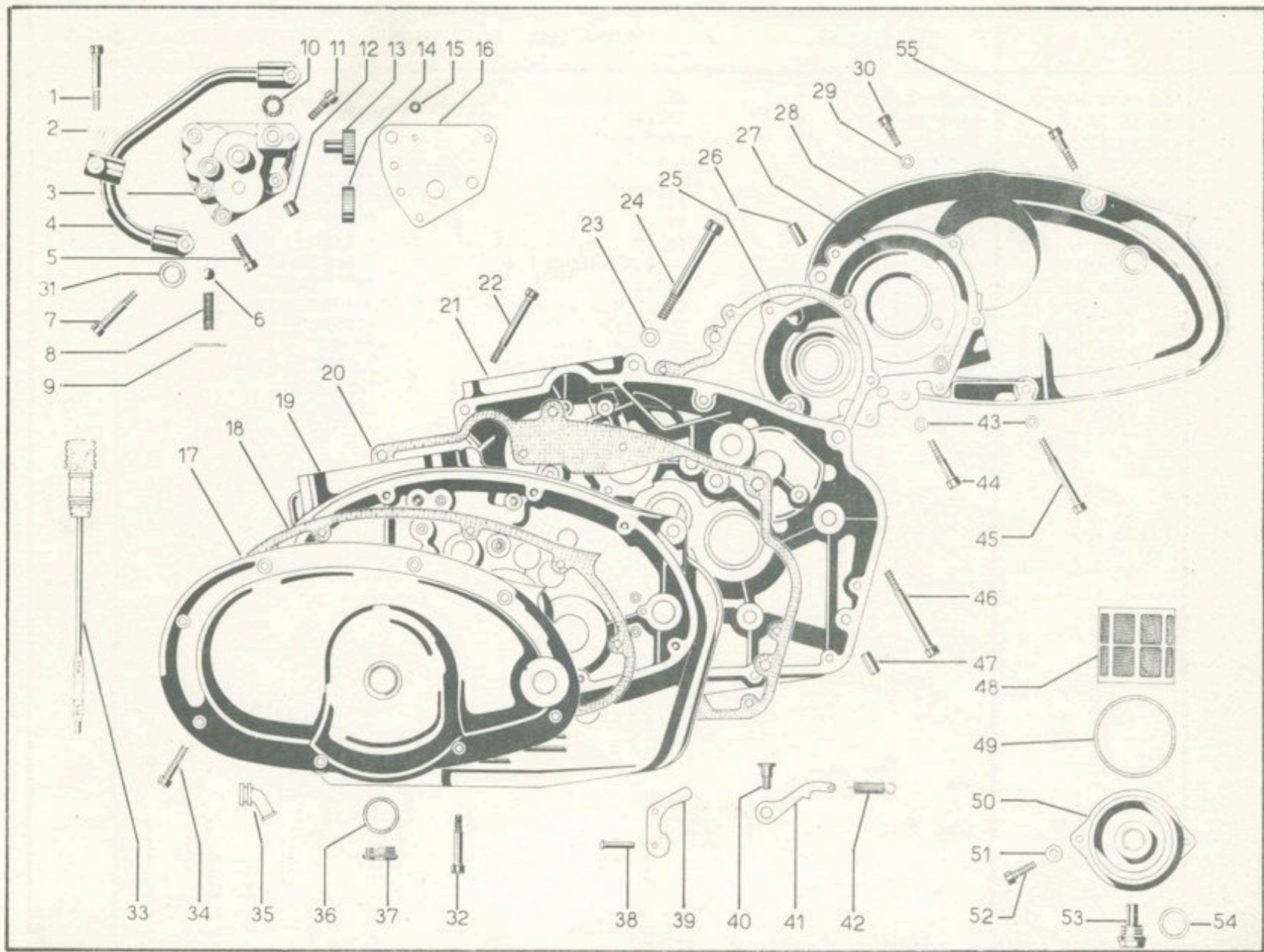

FIG.	ORD. N°	DESCRIZIONE	DESCRIPTION	DESCRIPTION	QT.
1	000 2162 01 3 3	VITE E.I. M6x45	VIS E.I.	SCREW	1
2	000 1101 06 4 3	RONDELLA Piana	RONDELLE	WASHER	3
3	211 06 003 0 00	CORPO pompa	CORPS de pompe	PUMP housing	1
4	211 06 005 0 80	TUBO aspirazione	TUYAU d'admission	SUCTION line	1
5	000 2158 01 3 3	VITE E.I. M6x25	VIS	SCREW	2
6	000 6397 11 1 0	SFERA 3/8	BIELLE	BALL	1
7	000 2160 01 3 3	VITE E.I. M6x35	VIS	SCREW	2
8	199 09 014 1 00	MOLLA valvola	RESSORT de soupape	VALVE spring	1
9	000 1131 18 2 0	COPIGLIA Ø1,8x20	GOUPILLE	COTTER pin	1
10	000 5600 13 1 0	GUARNIZIONE OR	JOINT OR	"O" RING	1
11	000 2156 01 3 3	VITE E.I. M6x20	VIS	SCREW	2
12	132 14 038 0 00	BOCCOLA centraggio	DOUILLE de centrage	BUSHING	2
13	211 06 002 0 00	INGRAN. condotto	ENGRENAGE conduit	DRIVEN gear	1
14	211 06 001 0 00	INGRAN. conduttore	ENGRENAGE conducteur	DRIVE gear	1
15	000 5600 04 1 0	GUARNIZIONE OR	JOINT OR	"O" ring	2
16	211 06 004 0 00	BASE pompa	BASE de la pompe	PUMP basement	1
17	211 02 005 0 00	COPERCHIO sinistro	COUVERCLE gauche	LH cover	1
18	211 02 006 0 00	GUARNIZIONE	JOINT	GASKET	1
19	213 02 002 0 80	CARTER sinistro	CARTER gauche	LH case	1
20	211 02 004 0 00	GUARNIZIONE	JOINT	GASKET	1
21	213 02 003 0 00	CARTER destro	CARTER droit	RH case	1
22	000 2165 01 3 3	VITE E.I. M6x60	VIS	SCREW	7
23	000 1125 01 0 0	RONDELLA piana	RONDELLE	WASHER	2
24	000 2265 01 3 3	VITE E.I. M8x80	VIS	SCREW	2
25	211 02 012 0 00	GUARNIZIONE	JOINT	GASKET	1
26	000 6398 10 0 0	RULLO	ERGOT	ROLLER	2
27	211 02 010 0 80	COPERCHIO camme	COUVERCLE comes	CAM cover	1
28	211 02 020 0 00	COPERCHIO destro	COUVERCLE droit	RH cover	1
29	000 1125 16 0 0	RONDELLA piana	RONDELLE	WASHER	5
30	000 2156 01 3 3	VITE E.I. M6x20	VIS	SCREW	5
31	000 5600 18 1 0	GUARNIZIONE OR	JOINT OR	"O" ring	1
32	000 2162 01 3 3	VITE E.I. M6x45	VIS	SCREW	2
33	211 06 007 0 80	ASTA livello	TIGE niveau	LEVEL stick	1
34	000 2159 01 3 3	VITE E.I. M6x30	VIS	SCREW	6
35	161 70 113 0 00	CAPPUCCIO fili	CHAPEAU de protection	WIRE cap	1
36	000 5606 03 0 0	GUARNIZIONE	JOINT	GASKET	1
37	122 05 059 1 00	TAPPO frizione	BOUCHON de l'embrayage	CLUTCH plug	1
38	000 1133 07 2 2	RIBATTINO Ø4x22	RIVET	RIVET	2
39	125 08 200 0 00	PIASTRINA saltarello	PLAQUETTE de la dent	PLATE	1

FIG.	ORD. N°	DESCRIZIONE	DESCRIPTION	DESCRIPTION	QT.
40	161 70 138 0 00	PERNO levetta	AXE du levier	LEVER hinge	1
41	136 19 367 0 00	LEVETTA	LEVIER	LEVER	1
42	136 19 152 0 00	MOLLA	RESSORT	SPRING	1
43	000 1125 16 0 0	RONDELLA piana	RONDELLE	WASHER	2
44	000 2160 01 3 3	VITE E.I.M6x35	VIS	SCREW	1
45	000 2165 01 3 3	VITE E.I.M6x60	VIS	SCREW	1
46	000 2167 01 3 3	VITE E.I.M6x70	VIS	SCREW	1
47	000 6398 10 0 0	RULLO	ERGOT	ROLLER	2
48	171 82 104 0 00	FILTRO olio	FILTRE huile	OIL filter	1
49	000 5607 44 1 0	GUARNIZIONE OR	JOINT OR	"O" ring	1
50	211 06 006 0 00	COPERCHIO filtro	COUVERCLE du filtre	FILTER cover	1
51	000 1101 06 4 3	RONDELLA piana	RONDELLE	WASHER	2
52	000 2156 01 3 3	VITE E.I.M6x20	VIS	SCREW	2
53	199 09 022 1 00	TAPPO magnetico	BOUCHON magnetique	MAGNETIC plug	1
54	000 5605 02 0 0	GUARNIZIONE	JOINT	GASKET	1
55	000 2159 01 3 3	VITE E.I.M6x30	VIS	SCREW	3

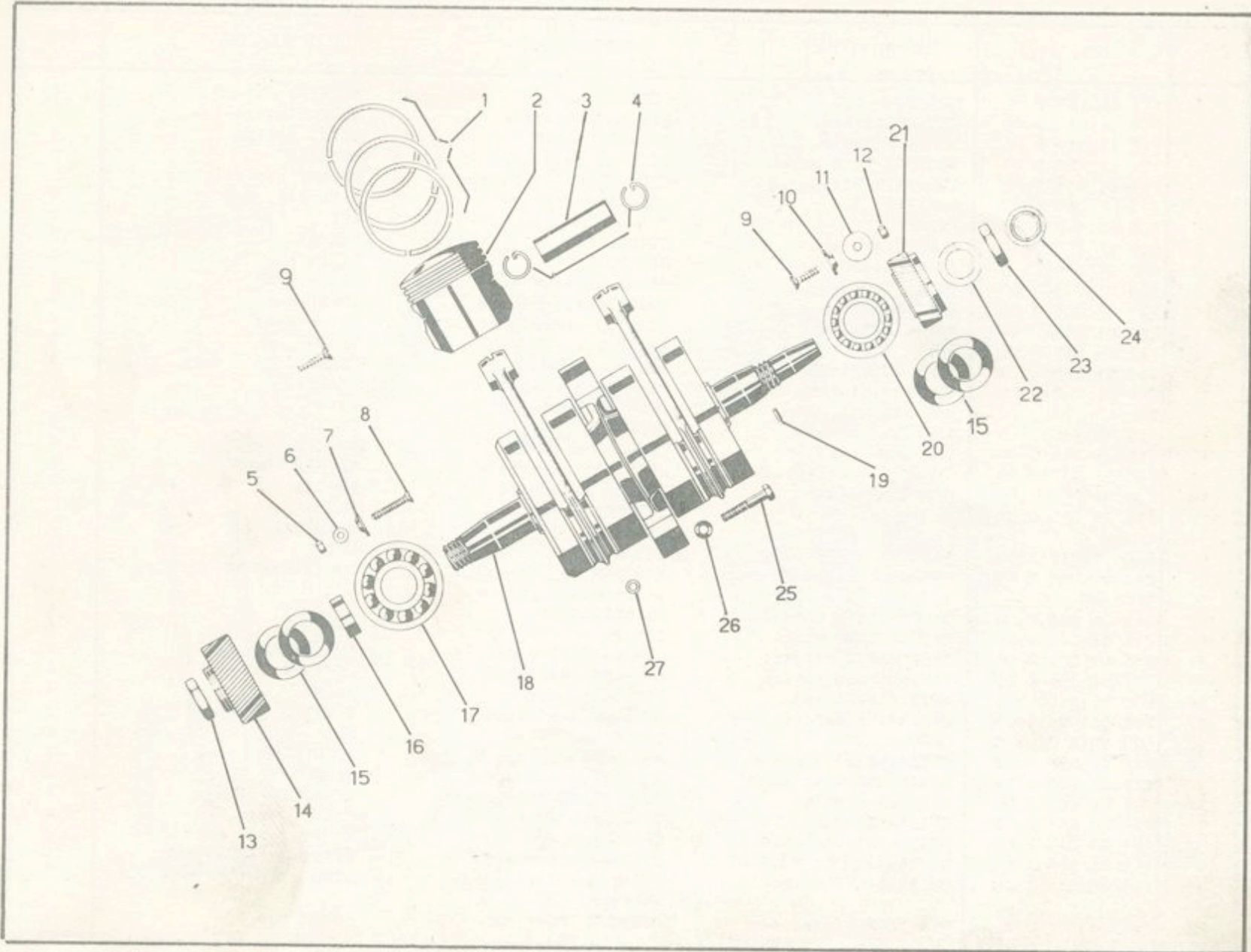

FIG.	ORD.N°	DESCRIZIONE	DESCRIPTION	DESCRIPTION	QT.	
1	213 03 010 0 01	FASCIA elastica AC Ø 65	SEGMENT de piston	PISTON ring	2	
	213 03 010 0 02	FASCIA elastica ROS Ø 65	SEGMENT de piston	PISTON ring	2	
	213 03 010 0 04	FASCIA elastica ROF Ø 65	SEGMENT de piston	PISTON ring	2	
	213 03 010 0 10	FASCIA elastica AC Ø 65,2	SEGMENT de piston	PISTON ring	2	
	213 03 010 0 11	FASCIA elastica ROS Ø 65,2	SEGMENT de piston	PISTON ring	2	
	213 03 010 0 12	FASCIA elastica ROF Ø 65,2	SEGMENT de piston	PISTON ring	2	
	213 03 010 0 13	FASCIA elastica AC Ø 65,4	SEGMENT de piston	PISTON ring	2	
	213 03 010 0 14	FASCIA elastica ROS Ø 65,4	SEGMENT de piston	PISTON ring	2	
	213 03 010 0 15	FASCIA elastica ROF Ø 65,4	SEGMENT de piston	PISTON ring	2	
	213 03 010 0 16	FASCIA elastica AC Ø 65,6	SEGMENT de piston	PISTON ring	2	
	213 03 010 0 17	FASCIA elastica ROS Ø 65,6	SEGMENT de piston	PISTON ring	2	
	213 03 010 0 18	FASCIA elastica ROF Ø 65,6	SEGMENT de piston	PISTON ring	2	
	2	213 03 010 0 80	PISTONE completo Ø 65	PISTON complet	PISTON	2
		213 03 010 1 80	PISTONE completo Ø 65,2	PISTON complet	PISTON	2
		213 03 010 2 80	PISTONE completo Ø 65,4	PISTON complet	PISTON	2
		213 03 010 3 80	PISTONE completo Ø 65,6	PISTON complet	PISTON	2
	3	213 03 010 0 03	SPINOTTO pistone	AXE de piston	PISTON pin	2
	4	161 70 091 0 05	ANELLINO	ANNEAU	CLIP	4
5	000 1011 05 2 3	DADO	ECROU	NUT	3	
6	000 1101 05 4 3	RONDELLA piana	RONDELLE	WASHER	3	
7	211 03 010 0 00	RONDELLA conica	RONDELLE conique	TAPER Washer	3	
8	000 3160 01 1 3	VITE T.S. M5x30	VIS	SCREW	2	
9	000 3159 01 1 3	VITE T.S. M5x25	VIS	SCREW	4	
10	211 03 010 0 00	RONDELLA conica	RONDELLE conique	TAPER Washer	3	
11	000 1106 05 4 3	RONDELLA piana	RONDELLE	WASHER	3	
12	000 1011 05 2 3	DADO	ECROU	NUT	1	
13	000 1050 00 2 3	DADO	ECROU	NUT	1	
14	211 03 011 0 00	PIGNONE frizione	PIGNON embrayage	CLUTCH pinion	4	
15	148 47 310 0 00	MOLLA tazza	RESSORT a tasse	CUP spring	1	
16	211 03 012 0 00	DISTANZIALE	ENTRETOISE	SPACER	1	
17	000 5771 01 1 3	CUSCINETTO 25x62x17	ROULEMENT	BEARING	1	
18	211 03 025 0 80	ALBERO motore composto	VILEBREQUIN	ENGINE shaft compl.	1	
19	000 6399 05 1 1	RULLO	EGUILLE	ROLLER	1	
20	000 6120 01 2 2	CUSCINETTO 25x52x18	ROULEMENT	BEARING	1	
21	211 03 020 0 00	PIGNONE camme	PIGNON de distribution	CAM pignon	1	
22	000 1125 34 0 0	RONDELLA piana	RONDELLE	WASHER	1	
23	000 1049 00 2 3	DADO	ECROU	NUT	1	
24	000 5603 34 0 1	GUARNIZIONE 17x28x6	JOINT	GASKET	1	
25	000 1362 01 3 3	VITE T.E. M6x35	VIS	SCREW	6	
26	000 1108 06 6 8	RONDELLA curvata	RONDELLE courbe	WASHER	6	
27	000 5600 04 1 0	GUARNIZIONE OR	JOINT OR	"O" ring	1	

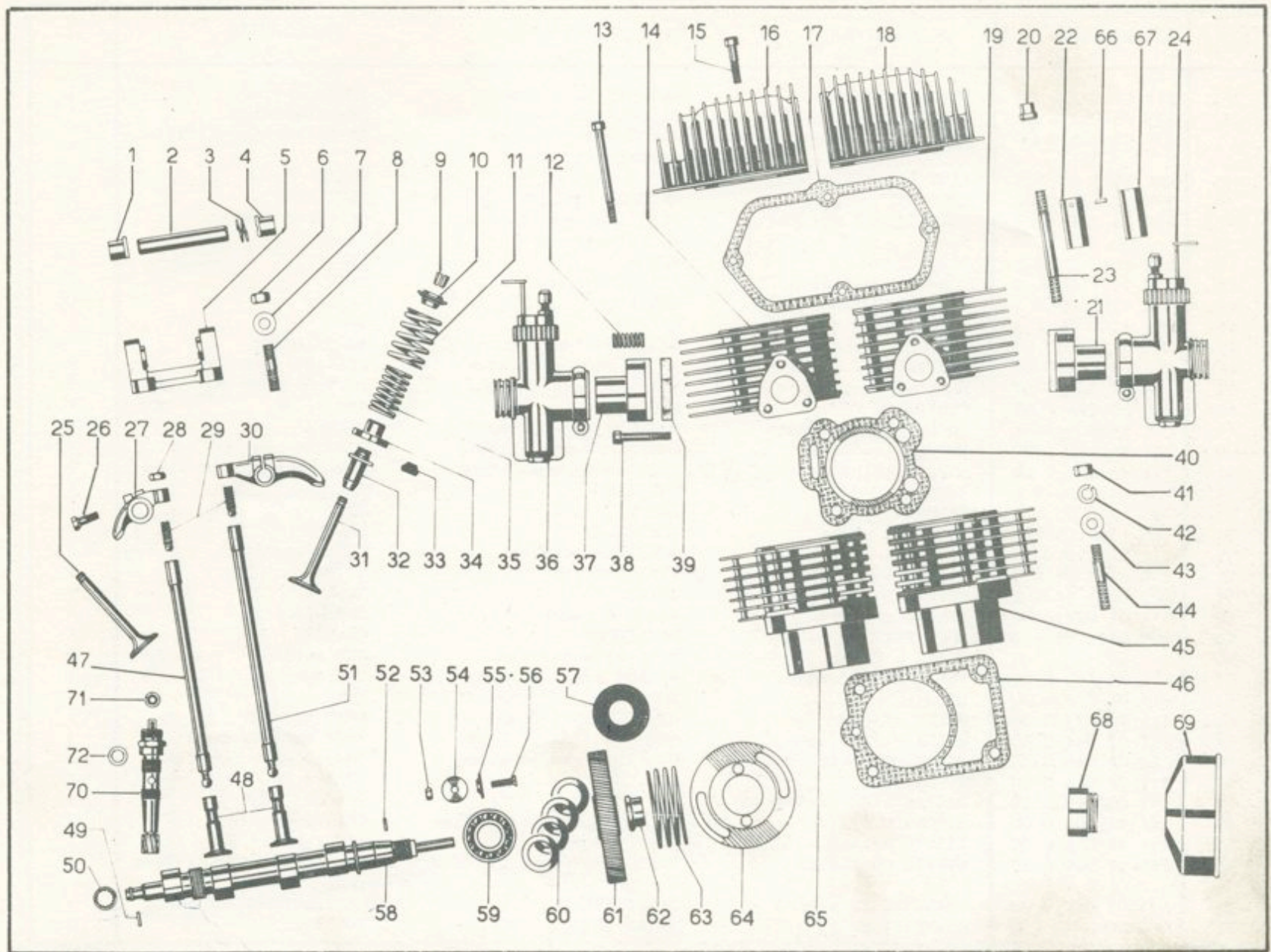

FIG.	ORD. N°	DESCRIZIONE	DESCRIPTION	DESCRIPTION	QT.
1	171 82 188 0 13	BOCCOLA	DOUILLE	BUSHING	4
2	211 04 010 0 00	PERNO bilancere	AXE du culbuteur	ROCKER hinge	4
3	148 47 017 0 00	MOLLA assiale	RESSORT axial	AXIAL spring	4
4	171 82 188 0 09	BOCCOLA lato asta	DOUILLE coté tige	BUSHING	4
5	211 04 011 0 80	SUPPORTO bilancere con fig. 1-4	SUPPORT du culbuteur avec fig. 1-4	ROCKER support with fig. 1-4	2
6	000 1011 08 2 3	DADO	ECROU	NUT	8
7	000 1101 08 4 3	RONDELLA piana	RONDELLE	WASHER	8
8	000 4100 42 3 3	PRIGIONIERO M8x37	GOIJON	STUD	8
9	199 03 028 0 00	SEMICONO	BAGUE conique en 2 pieces	HALF-CONE	4
10	211 04 007 0 00	PIATTELLO superiore	CUVETTE superieure	UPPER cap	4
11	211 04 013 0 00	MOLLA esterna	RESSORT estèrieure	EXT spring	4
12	122 05 035 0 00	MOLLA	RESSORT	SPRING	6
13	000 2168 01 3 3	VITE E.I.M6x75	VIS	SCREW	4
14	213 04 002 0 80	TESTA sinistra con fig. 32	CULASSE gauche avec fig. 32	LH-HEAD with fig. 32	1
15	000 2159 01 3 3	VITE E.I.M6x30	VIS	SCREW	4
16	211 04 015 0 00	CAPPELLO sinistro	COUVERCLE gauche	LH-CAP	1
17	211 04 017 0 00	GUARNIZIONE cappello	JOINT du couvercle	GASKET	2
18	211 04 016 0 00	CAPPELLO destro	COUVERCLE droite	RH-CAP	1
19	213 04 003 0 80	TESTA destra con fig. 32	CULASSE droite avec fig. 32	RH-HEAD with fig. 32	1
20	211 04 047 0 00	DADO	ECROU	NUT	8
21	213 05 006 0 00	RACCORDO carburatore sin.	MANCHON de raccord du carburateur gauche	LH-CARBURATOR fitting	1
22	211 04 043 0 00	DISTANZIALE sottodado	ENTRETOISE	SPACER	4
23	211 04 048 1 00	PRIGIONIERO M8x90	GOIJON	STUD	8
24	213 05 002 0 02	CARBURATORE destro	CARBURATEUR droit	RH-CARBURATOR	1
25	211 04 004 0 00	VALVOLA aspirazione	SOUPAPE admission	SUCTION valve	2
26	000 5513 00 3 3	VITE fissaggio	VIS de fissage	SCREW	4
27	211 04 008 0 00	BILANCERE aspirazione	CULBUTEUR admission	SUCTION rocker	2
28	000 1013 07 2 3	DADO	ECROU	NUT	4
29	211 04 020 0 00	VITE registro gioco	VIS pour reglage du jeu	ADJUSTING screw	4
30	211 04 009 0 00	BILANCERE scarico	CULBUTEUR echappement	EXHAUST rocker	2
31	211 04 005 0 00	VALVOLA scarico	SOUPAPE d'echappement	EXHAUST valve	2
32	161 70 015 2 00	GUIDA-valvola	GUIDE soupape	VALVE guide	4
	161 70 015 2 01	GUIDA-valvola +0,1	GUIDE soupape +0,1	VALVE guide +0,1	4
	161 70 015 2 02	GUIDA-valvola +0,2	GUIDE soupape +0,2	VALVE guide +0,2	4
33	161 70 016 0 00	GUARNIZIONE su stelo	JOINT sur la tige de soupape	STEM gasket	4
34	211 04 006 0 00	PIATTELLO inferiore	CUVETTE infèrieure	LOWER cap	4

FIG.	ORD. N°	DESCRIZIONE	DESCRIPTION	DESCRIPTION	QT.
35	211 04 012 0 00	MOLLA interna	RESSORT intérieur	INNER spring	4
36	213 05 002 0 01	CARBURATORE sinistro	CARBURATEUR gauche	LH-carburator	1
37	213 05 005 0 00	RACCORDO carburatore des.	MANCHON de raccord du carburateur droit	RH-carburator fitting	1
38	000 2161 01 3 3	VITE E.I.M6x40	VIS	SCREW	6
39	199 04 033 0 00	ISOLANTE raccordo	RACCORD isolant	INSULATOR	2
40	213 01 046 0 00	GUARNIZIONE cil-testa	JOINT entre cylindre et culasse	CYL-head gasket	2
41	000 1012 08 2 3	DADO	ECROU	NUT	8
42	000 1111 08 6 3	RONDELLA elastica	RONDELLE elastique	CLIP	8
43	000 1101 08 4 3	RONDELLA piana	RONDELLE	WASHER	8
44	000 4100 36 3 3	PRIGIONIERO M8x52	COUJON	STUD	8
45	213 04 042 0 80	CILINDRO destro comp.	CYLINDRE droit complet	RH-cylinder	1
46	213 04 045 0 00	GUARNIZIONE cilindro	JOINT entre cylindre	CYL-case gasket	2
47	211 04 021 0 80	ASTA aspirazione comp.	TIGE admission comp.	SUCTION push rod comp.	2
48	211 04 026 0 00	PUNTALINO	POUSSOIR	CAP	4
49	000 6399 04 1 1	RULLO trascinamento	ERGOT d'entraînement	ROLLER	1
50	161 70 146 1 00	BOCCOLA rullini	DOUILLE à aiguilles	BUSHING	1
51	211 04 025 0 80	ASTA scarico comp. 25.80	TIGE echappement comp.	EXHAUST push rod comp.	2
52	000 6399 05 1 1	RULLO	EGUILLE	ROLLER	1
53	000 1011 05 2 3	DADO	ECROU	NUT	2
54	000 1106 05 4 3	RONDELLA piana	RONDELLE	WASHER	1
55	211 03 010 0 00	RONDELLA conica	RONDELLE conique	TAPER washer	2
56	000 3158 01 1 3	VITE T.S.M5x20	VIS	SCREW	2
57	000 5603 11 0 1	GUARNIZIONE 22x45x7	JOINT	GASKET	1
58	211 04 027 0 00	ALBERO camme	ARBRE à cames	CAMSHAFT	1
59	000 5693 01 1 2	CUSCINETTO 20x42x12	ROULEMENT	BEARING	1
60		MOLLA a tazza	RESSORT à cuvette	CUP spring	2
61	213 04 030 0 00	INGRANAGGIO camme	PIGNON arbre à cames	CAM gear	1
62	211 04 032 0 00	DADO	ECROU	NUT	1
63	211 04 033 0 00	MOLLA sfiato	RESSORT de l'évant	VENT spring	1
64	211 04 034 0 80	MOLLA sfiato comp.	SOUPAPE d'évant comp.	VENT valve-complete	1
65	213 04 040 0 80	CILINDRO sinistro comp.	CYLINDRE gauche comp.	LH-cylinder complete	1
66	211 04 044 0 00	RULLO	EGUILLE	ROLLER	4
67	211 04 049 0 00	DISTANZIALE sottodado	ENTRETOISE	SPACER	4
68	211 12 004 0 00	RACCORDO distanziale	RACCORD de l'entretoise	SPACER fitting	2
69	211 12 005 0 00	FILTRO aria	FILTRE à air	AIR filter	2
70	211 11 001 0 80	RINVIO contagiri	RENVOLY de come-tours	R.P.H. counter driving gear	1
71	199 03 047 0 00	GUARNIZIONE albero	JOINT arbre	GASKET shaft	1
72	000 5600 13 1 0	GUARNIZIONE OR	JOINT OR	"O" ring	1

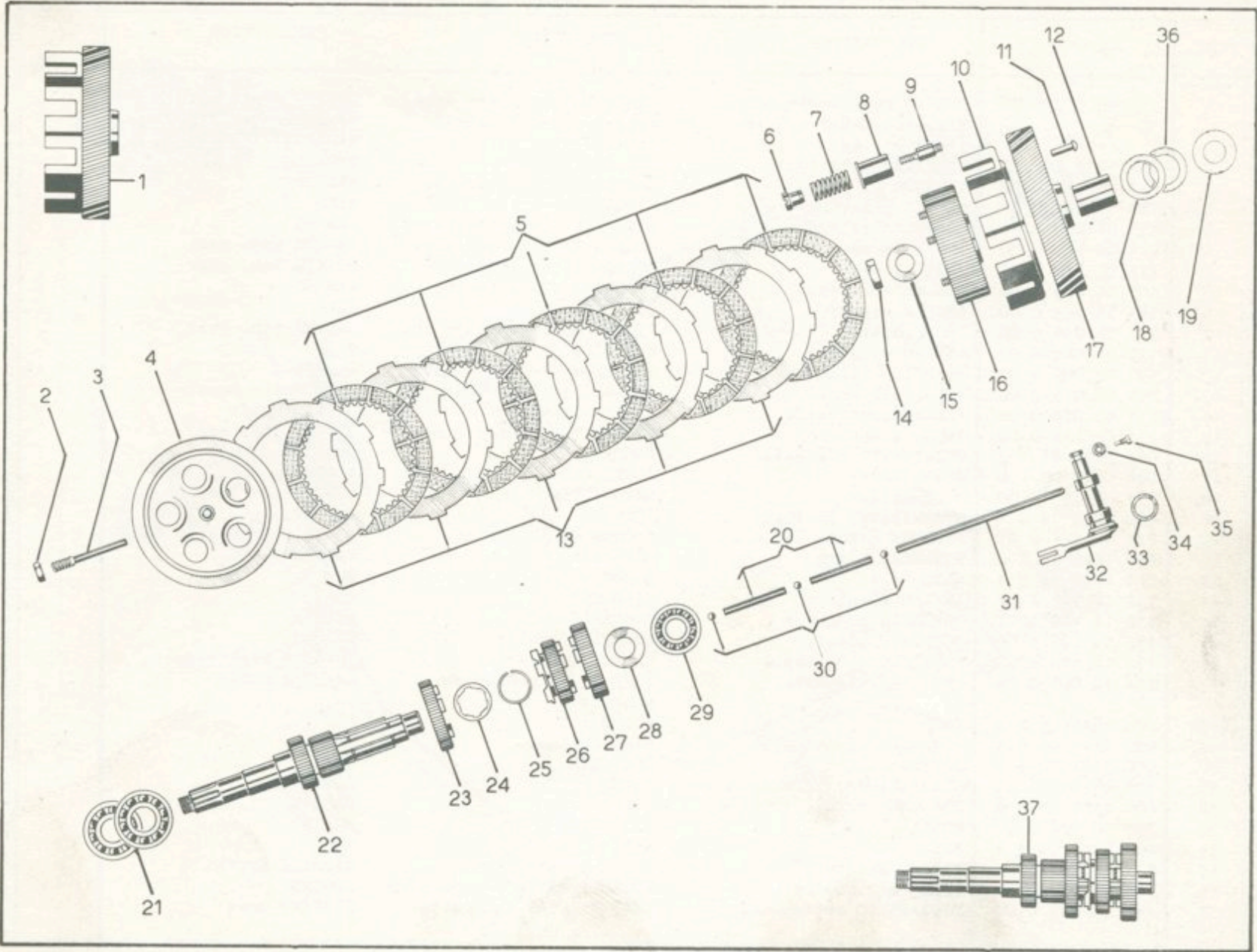

FIG.	ORD. N°	DESCRIZIONE	DESCRIPTION	DESCRIPTION	QT.
1	211 07 001 0 80	INGRANAGGIO frizione con fig. 10	PIGNON embrayage avec fig. 10	CLUTCH gear with fig. 10	1
2	000 1015 08 2 3	DADO	ECROU	NUT	1
3	169 81 102 1 00	VITE regolaggio	VIS de réglage	ADJUSTING screw	1
4	211 07 012 0 00	DISCO premifrizione	DISQUE de la butée	CLUTCH disc	1
5	211 07 009 0 00	DISCO condotto	DISQUE conduit	DRIVEN disc	5
6	169 81 094 1 00	DADO	ECROU	NUT	5
7	199 05 013 0 00	MOLLA	RESSORT	SPRING	5
8	171 82 459 0 00	PONDELLO	COVERCLE	BOTTOM	5
9	211 07 004 0 00	COLONNINA	AXE	COLUMN	5
10	171 82 453 0 00	CUSTODIA frizione	BOITE embrayage	CLUTCH housing	1
11	000 1133 08 1 8	RIBATTINO	RIVET	RIVET	8
12	211 07 002 0 00	BOCCOLA distanziale	BAGUE entretoise	SPACER	1
13	171 82 458 0 00	DISCO conduttore	DISQUE conducteur	DRIVEN disc	5
14	000 1035 00 2 3	DADO	ECROU	NUT	1
15	000 1125 60 0 0	RONDELLA piana	RONDELLE	WASHER	1
16	211 07 003 0 80	ROCCHETTO friz. con fig. 9	PIGNON embrayage avec fig. 9	CLUTCH sprocket with fig. 9	1
17	211 07 001 0 00	INGRANAGGIO frizione	PIGNON embrayage	CLUTCH gear	1
18	000 1125 77 0 0	RONDELLA rasamento 1,1	RONDELLE de réglage	WASHER	1
19	000 1125 66 0 0	RONDELLA fra cusc. e boccola	RONDELLE entre roulement et douille	WASHER between bearing and bushing	1
20	171 82 456 0 00	ASTA centrale	TIGE centrale	ROD	2
21	000 5735 01 1 3	CUSCINETTO 20x47x14	ROULEMENT	BEARING	2
22	211 08 001 0 00	ALBERO primario	ARBRE primaire	DRIVE shaft	1
23	211 08 002 0 00	INGRANAGGIO IV prim.	PIGNON IV prim.	4th. DRIVE gear	1
24	199 06 005 0 00	RONDELLA ritegno	ARRETOIR	WASHER	1
25	151 51 073 0 00	ANELLO elastico	CIRCLIP	CLIP	1
26	211 08 003 0 00	INGRANAGGIO scorr. III p.	PIGNON coulissant III p.	Ed. DRIVE gear	1
27	211 08 004 0 00	INGRANAGGIO V prim.	PIGNON V prim.	5th. DRIVE gear	1
28	171 82 186 0 04	RONDELLA	RONDELLE	WASHER	1
29	000 5734 01 1 2	CUSCINETTO 17x40x12	ROULEMENT	BEARING	1
30	000 6397 05 1 0	SFERA 3/16	DOUILLE	BALL	3
31	211 07 010 0 00	ASTA esterna	TIGE exterieure	EXT. rod	1
32	211 07 011 0 00	LEVA frizione	LEVIER embrayage	CLUTCH lever	1
33	000 5600 20 1 0	GUARNIZIONE OR	JOINT OR	"O" ring	1
34	000 1126 11 0 0	RONDELLA	RONDELLE	WASHER	1
35	000 5517 00 0 0	VITE fermo leva	VIS d'arrêt du levier	SCREW	1
36	000 1125 75 0 0	RONDELLA rasamento 1,2	RONDELLE de réglage	WASHER	1
37	211 08 001 0 80	ALBERO prim. con fig. 23-24-25-26-27-28	ARBRE prim. avec fig. 23-24-25-26-27-28	DRIVE shaft with fig. 23-24-25-26-27-28	1

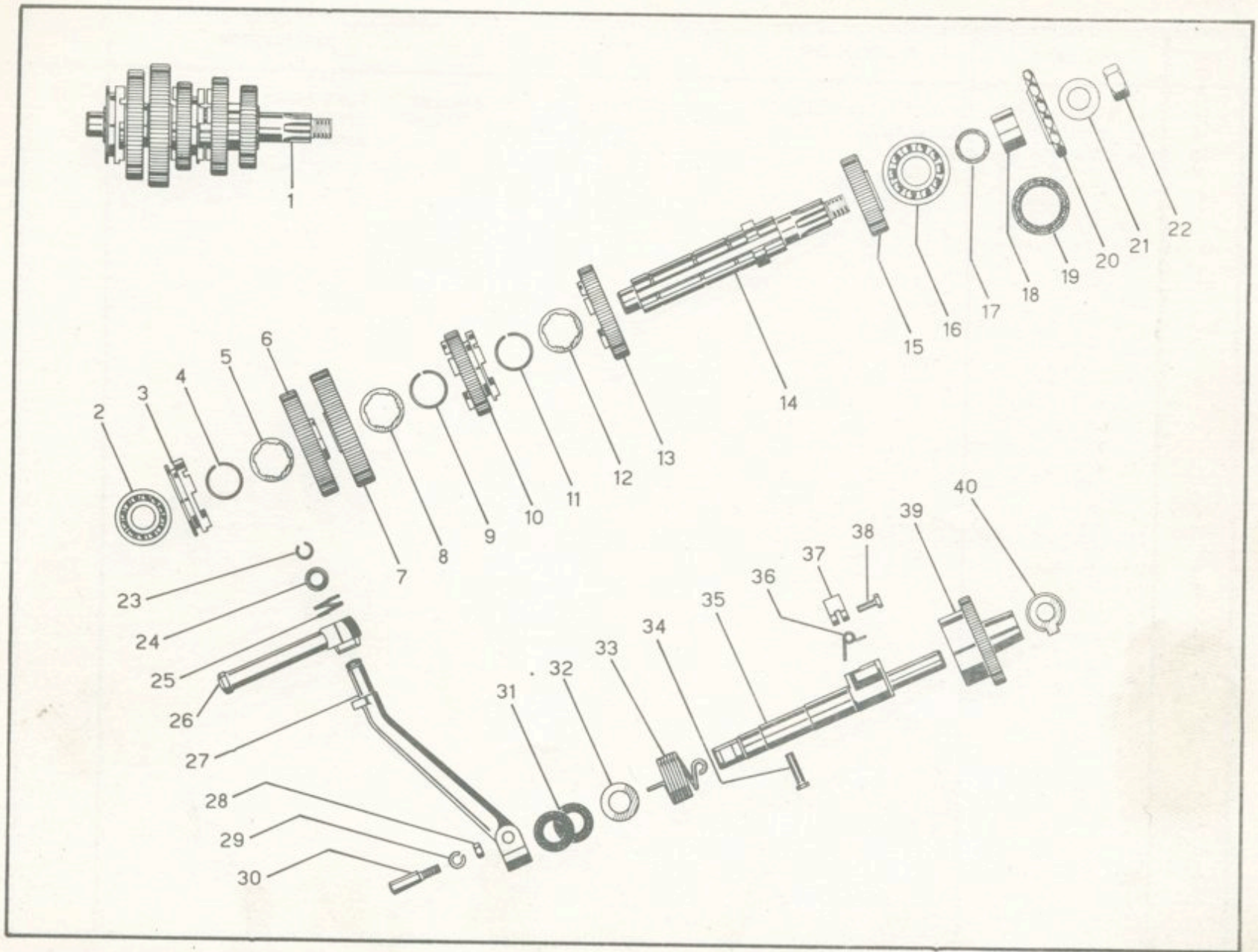

FIG..	CRD. N°	DESCRIZIONE	DESCRIPTION	DESCRIPTION	QT.
1	211 08 010 0 80	ALBERO secondario con fig. 3-4-5-6-7-8-9-10-11-12-13-14	ARBRE intermédiaire avec fig. 3-4-5-6-7-8-9-10-11-12-13-14	DRIVEN shaft with fig. 3-4-5-6-7-8-9-10-11-12-13-14	1
2	000 5734 01 1 2	CUSCINETTO 17x40x18	ROULEMENT	BEARING	1
3	211 08 011 0 00	INNESTO II sec.	EMBAYAGE II interméd.	SLIDER	1
4	151 51 063 0 00	ANELLO elastico	CIRCLIP	CLIP	1
5	199 06 005 0 00	RONDELLA ritegno	RONDELLE d'etancheité	WASHER	1
6	211 08 012 0 00	INGR. II sec.	PIGNON II intermédiaire	DRIVEN 2nd. gear	1
7	211 08 013 0 00	INGR. I sec.	PIGNON I intermédiaire	DRIVEN 1st. gear	1
8	199 06 005 0 00	RONDELLA ritegno	RONDELLE d'etencheité	WASHER	1
9	151 51 063 0 00	ANELLO elastico	CIRCLIP	CLIP	1
10	211 08 014 0 00	INGR. scorr. IV sec.	PIGNON coulissant IV int.	DRIVEN 4th. gear	1
11	151 51 063 0 00	ANELLO elastico	CIRCLIP	CLIP	1
12	199 06 005 0 00	RONDELLA ritegno	RONDELLE d'etancheité	WASHER	1
13	211 08 015 0 00	INGR. III sec.	PIGNON III intermédiaire	DRIVEN 3rd. gear	1
14	211 08 010 0 00	ALBERO secondario	ARBRE secondaire	DRIVEN shaft	1
15	211 08 016 0 00	INGR. V sec.	PIGNON V intermédiaire	DRIVEN 5th. gear	1
16	000 5735 01 1 3	CUSCINETTO 20x47x14	ROULEMENT	BEARING	1
17	000 5607 08 1 0	GUARNIZIONE OR	JOINT OR	"O" ring	1
18	211 08 020 0 00	DISTANZIALE	ENTRETOISE	SPACER	1
19	000 5603 36 0 1	GUARNIZIONE 28x40x7	JOINT	GASKET	1
20	211 08 021 0 01	PIGNONE catena Z15	PIGNON de la chaine	CHAIN pignon gear	1
21	000 1125 60 0 0	RONDELLA piana	RONDELLE	WASHER	1
22	000 1014 14 2 3	DADO	ECROU	NUT	1
23	132 14 180 1 02	ANELLO elastico	CIRCLIP	CLIP	1
24	132 14 180 1 01	RONDELLA appoggio	RONDELLE	WASHER	1
25	132 14 181 1 00	DOPPIA rondella	RONDELLE double	WASHER	1
26	132 14 179 0 00	PEDALINO ribaltabile	PEDALE du starter	MOVABLE kick pedal	1
27	211 10 005 0 00	PEDALE avviamento	TIGE de la pedale du starter	STARTER pedal	1
28	000 1013 06 2 3	DADO	ECROU	NUT	1
29	000 1111 06 6 3	RONDELLA elastica	CIRCLIP	CLIP	1
30	000 5531 00 3 7	BIETTA	CLAVETTE	KEY	1
31	125 08 090 1 01	GUARNIZIONE 17x28x45	JOINT	GASKET	2
32	000 1125 39 0 0	RONDELLA piana	RONDELLE	WASHER	1
33	125 08 074 0 00	MOLLA	RESSORT	SPRING	1
34	000 5107 00 1 3	SPINA	AXE	PIN	1
35	211 10 002 0 00	ALBERO avviamento	ARBRE du starter	STARTER shaft	1
36	148 47 158 0 00	MOLLA saltarello	RESSORT de la dent d'arr.	SPRING	1
37	148 47 157 0 00	SALTARELLO avviamento	DENT d'arrêt du starter	STARTER pawl	1

FIG.	ORD. N°	DESCRIZIONE	DESCRIPTION	DESCRIPTION	QT.
38	143 31 116 0 00	PERNO saltarello	GUJON de la dent d'arrêt	PAWL hinse	1
39	211 10 001 0 00	INGRANAGGIO avviam.	PIGNON du starter	STARTER gear	1
40	129 11 028 0 00	RONDELLA	RONDELLE	WASHER	1

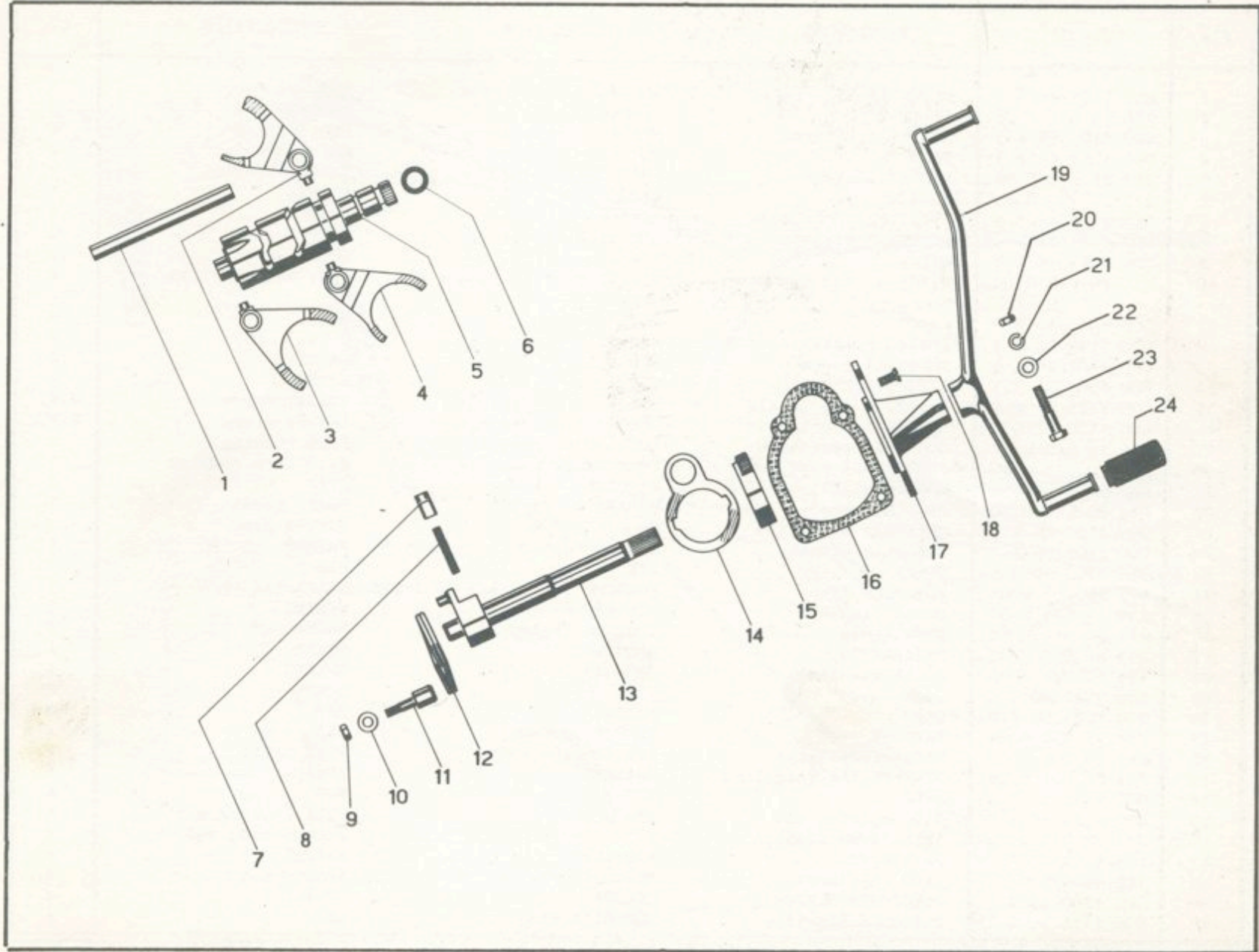

FIG.	ORD. N°	DESCRIZIONE	DESCRIPTION	DESCRIPTION	QT.
1	211 09 004 0 00	PERNO forcellino	AXE de la fourchette	FORK hinge	2
2	211 09 003 0 00	FORCELLINO IV - V vel.	FOURCHETTE IV - V vitesse	FORK 4th - 5th gear	1
3	211 09 001 0 00	FORCELLINO II vel.	FOURCHETTE II vitesse	FORK 2nd gear	1
4	211 09 002 0 00	FORCELLINO I - III vel.	FOURCHETTE I-III vitesse	FORK 1st - 3rd gear	1
5	211 09 005 0 00	CAMMA cambio	CAME du changement de vitesse	CAM	1
6	000 5600 16 1 C	GUARNIZIONE OR	JOINT OR	"O" ring	1
7	125 08 069 0 00	SALTARELLO selettore	DENTE du sélecteur	SELECTOR	2
8	125 08 065 0 01	MOLLA saltarello	RESSORT de la dente	SPRING	1
9	000 1013 06 2 3	DADO	ECRCU	NUT	1
10	000 1101 06 4 3	RONDELLA piana	RONDELLE	WASHER	1
11	211 09 014 0 00	PICLO fermo molla	CHEVILLE d'arrêt du ressort	SPRING holder	1
12	125 08 071 0 00	MOLLA albero	RESSORT de l'arbre	SPRING	1
13	211 09 010 0 80	ALBERO selettore	ARBRE selecteur	SELECTOR shaft	1
14	211 09 011 0 00	PIASTRINA	PLAQUETTE	PLATE	1
15	211 09 006 0 00	SETTORE camma	SECTEUR came	CAM sector	1
16	211 02 022 0 00	GUARNIZIONE	JOINT	GASKET	1
17	211 02 021 0 00	COPERCHIO selettore	COUVERCLE du sélecteur	COVER	1
18	000 3228 01 3 3	VITE T.S. M6x16	VIS	SCREW	4
19	211 09 012 0 00	PEDALE cambio	PEDALE du changement de v.	GEAR change pedal	1
20	000 1013 06 2 3	DADO	ECROU	NUT	1
21	000 1111 06 6 3	RONDELLA elastica	RONDELLE elastique	CLIP	1
22	000 1101 06 4 3	RONDELLA piana	RONDELLE	WASHER	1
23	000 1362 01 3 3	VITE T.E. M6x35	VIS	SCREW	1
24	129 11 312 0 00	PEDALINO gomma	PEDALE en caoutchouc	RUBBER footrest	2

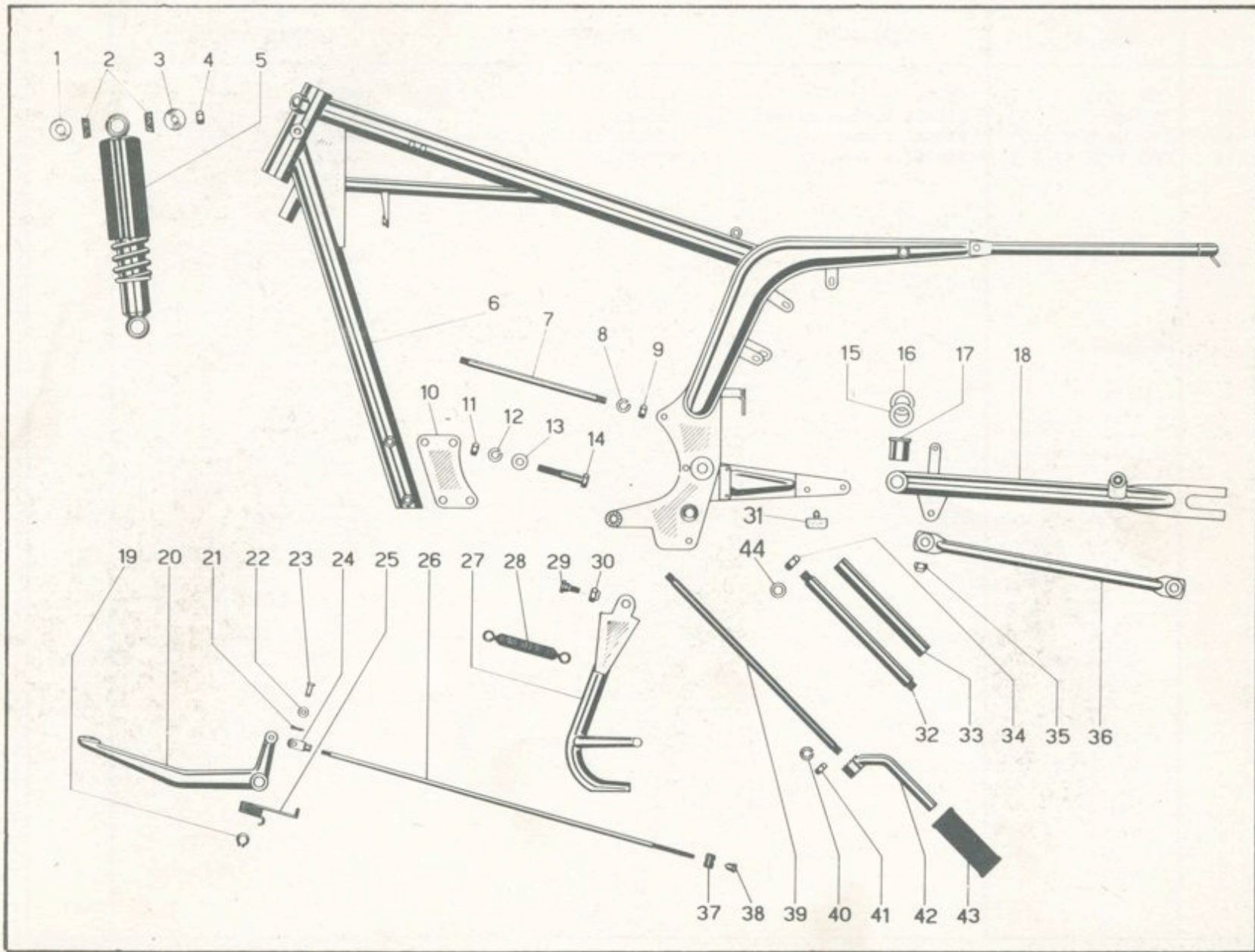

FIG.	ORD. N°	DESCRIZIONE	DESCRIPTION	DESCRIPTION	QT.
1	000 1101 12 4 3	RONDELLA interna	RONDELLE interieure	INT. washer	3
2	136 19 631 0 00	SILENTBLOC	TAMPON	SILENTBLOCK	8
3	000 1105 08 4 3	RONDELLA esterna	RONDELLE exterieure	EXT. washer	4
4	000 1011 08 2 3	DADO	ECROU	NUT	4
5	213 20 013 0 00	AMMORTIZZATORE	AMORTISSEUR	SHOCK absorber	2
6	213 20 100 0 80	TELAIO	CADRE	FRAME	1
7	000 4100 39 3 3	PRIGIONIERO M10x212	GOIJON	STUD	1
8	000 1111 10 6 3	RONDELLA elastica	RONDELLE elastique	CLIP	2
9	000 1013 10 2 3	DADO	ECROU	NUT	2
10	211 20 002 0 00	PIASTRA attacco motore	PLAQUE pour le fixage du moteur	ENG. attach plate	2
11	000 1013 10 2 3	DADO	ECROU	NUT	4
12	000 1111 10 6 3	RONDELLA elastica	RONDELLE elastique	CLIP	4
13	000 1101 10 4 3	RONDELLA piana	RONDELLE	WASHER	4
14	000 1563 01 3 3	VITE T.E.M10x65	VIS	SCREW	4
15	000 1125 61 0 0	RONDELLA regolaggio	RONDELLE de réglage	ADJUST screw	S.V.
16	000 1125 62 0 0	RONDELLA regolaggio	RONDELLE de réglage	ADJUST screw	S.V.
17	136 19 848 0 01	BOCCOLA forcellone	DOUILLE fourche AR	FORK bushing	2
18	213 20 011 0 80	FORCELLONE post. comp.	POURCHE AR complète	REAR fork complet	1
19	000 5064 13 0 0	ANELLO elastico	CIRCLIP	CLIP	1
20	211 20 010 0 80	PEDALE freno	PEDALE du frein	BRAKE pedal	1
21	000 1131 18 1 8	COPIGLIA Ø 1,8x18	GOUPILLE	COTTER pin	1
22	000 1101 06 4 3	RONDELLA piana	RONDELLE	WASHER	1
23	000 5103 00 3 3	SPINA	AXE	PIN	1
24	199 10 101 0 01	FORCELLA freno	POURCHE de la tige du frein	BRAKE rod fork	1
25	136 19 629 0 00	MOLLA richiamo	RESSORT de rappel	SPRING	1
26	211 20 014 0 00	ASTA freno	TIGE du frein	BRAKE rod	1
27	213 20 010 0 80	CAVALLETTO	BEQUILLE	STAND	1
28	199 10 076 0 00	MOLLA richiamo	RESSORT du rappel	SPRING	1
29	000 5542 00 3 3	VITE	VIS	SCREW	2
30	000 1023 08 1 0	DADO	ECROU	NUT	2
31	214 11 056 0 00	TAMPONE	TAMPON	PAD	1
32	211 20 006 0 00	PERNO forcellone	AXE fourche AR	FORK hinge	1
33	211 20 007 0 00	DISTANZIALE rotazione	ENTRETOISE	SPACER	1
34	000 1014 12 2 3	DADO	ECROU	NUT	2
35	000 1023 10 1 0	DADO autofrenato	ECROU autobloquant	SELF locking nut	1
36	211 25 015 0 80	ASTA fermo flangia	TIGE d'arrêt de la bride	FLANGE stop rod	1
37	163 53 030 0 00	BARILETTO	BARILLET	BARREL	1
38	163 53 025 0 00	DADO regolaggio	ECROU de réglage	ADJUST nut	1
39	000 4100 44 3 3	PRIGIONIERO M10x345	GOIJON	STUD	1
40	000 1111 10 6 3	RONDELLA elastica	RONDELLE elastique	CLIP	2

FIG.	ORD. N°	DESCRIZIONE	DESCRIPTION	DESCRIPTION	QT.
41	000 1013 10 2 3	DADO	ECROU	NUT	2
42	211 20 003 0 00	PEDANA appoggiapiedi	PEDANE	FOOT rest	2
43	172 84 528 0 00	PEDANA gomma	PEDANE en caoutchouc	RUBBER foot rest	2
44	000 1115 12 6 3	RONDELLA dentata	RONDELLE	SCREW	2

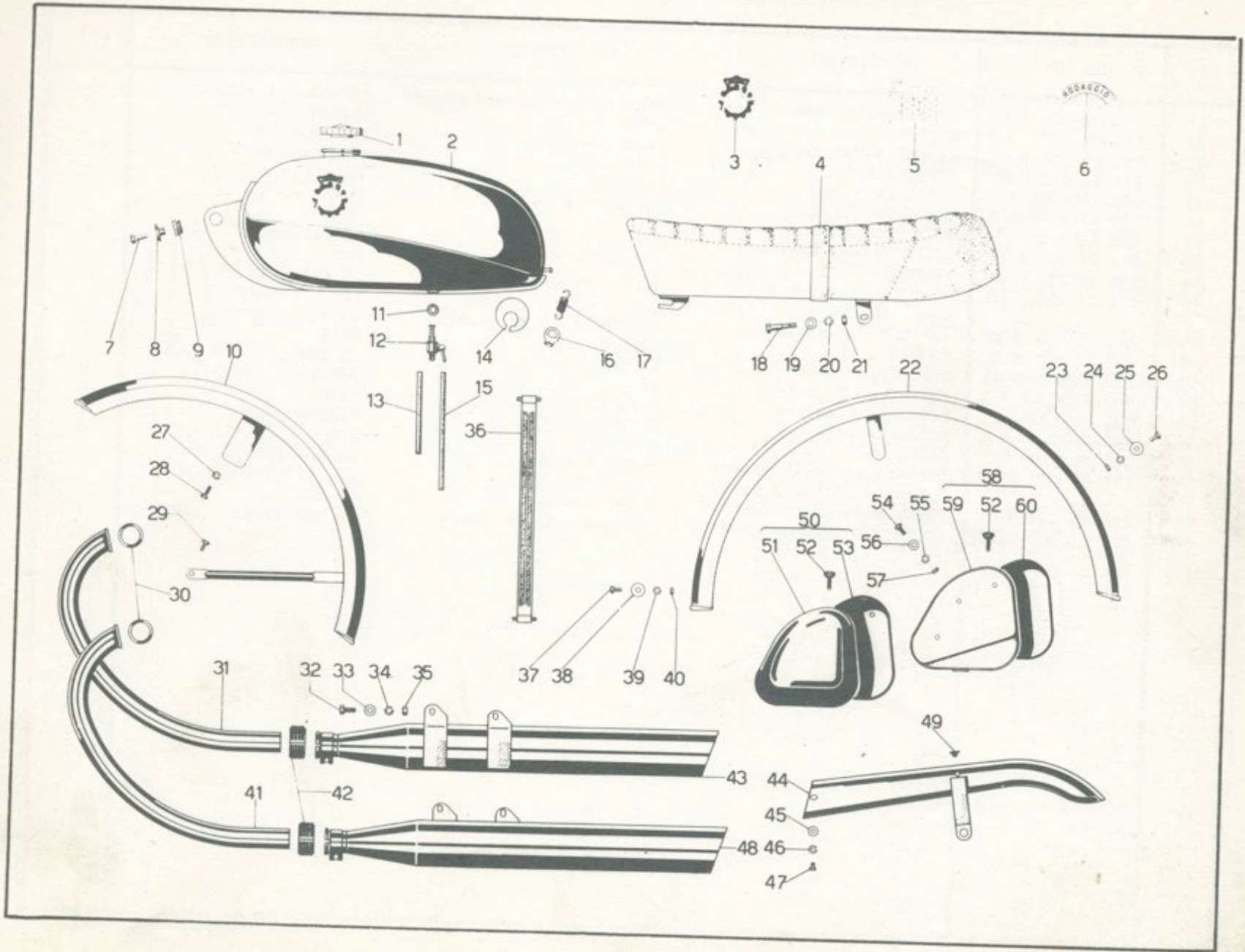

FIG.	CRD. N°	DESCRIZIONE	DESCRIPTION	DESCRIPTION	QT.
1	136 19 761 0 00	TAPPO serbatoio	BOUCHON du Réservoir	FUEL Filler cap	1
2	213 21 100 0 00	SERBATOIO	RESERVOIR	TANK	1
3	172 84 561 0 00	CALCOMANIA "MV"	DECALCOMANIE"IV"	"MV" decal	2
4	213 21 102 0 00	SELLA	SELLE	SADDLE	1
5	172 84 564 0 00	CALCOMANIA"trofei"	DECALCOMANIE"trophées"	"TROPHIES" decal	1
6	136 19 619 0 00	CALCOMANIA"rodaggio"	DECALCOMANIE"rodage"	"BREAK-IN" decal	1
7	000 1455 01 3 3	VITE T.E. M8x22	VIS	SCREW	2
8	172 84 572 0 00	DISTANZIALE	ENTRETOISE	SPACER	2
9	172 84 574 0 00	SILENTBLOC	TAMPON	SILENTBLOC	2
10	211 28 010 0 00	PARAFANGO ant.	GARDE-BOUE av.	FRONT mud guard	1
11	000 1126 03 0 0	RONDELLA fibra	RONDELLE en fibre	FIBRE washer	2
12	000 5307 00 0 0	ROBINETTO benzina	ROBINET à essence	FUEL tap	2
13	000 5539 01 4 0	TUBO benzina L=140	TUYAU essence	FUEL LINE	2
14	136 19 869 0 00	SILENTBLOC appoggio serb.	COUSSIN appui reservoir	RUBBER tank pillow	1
15	000 5539 02 0 0	TUBO benzina L=200	TUYAU essence	FUEL LINE	1
16	136 19 909 0 00	GANCIO	VERROU	HOOK	2
17	136 19 862 0 00	MOLLA	RESSORT	SPRING	2
18	000 1459 01 3 3	VITE T.E. M8x35	VIS	SCREW	2
19	000 1111 08 4 3	RONDELLA piana	RONDELLE	WASHER	2
20	000 1111 08 6 3	RONDELLA elastica	RONDELLE elastique	CLIP	2
21	000 1011 08 2 3	DADO	ECROU	NUT	2
22	213 21 001 0 00	PARAFANGO posteriore	GARDE-BOU ar.	REAR mudguard	1
23	000 1013 06 2 3	DADO	ECROU	NUT	1
24	000 1111 06 6 3	RONDELLA elastica	RONDELLE elastique	CLIP	1
25	000 1125 09 0 0	RONDELLA piana	RONDELLE	WASHER	1
26	000 1354 01 3 3	VITE T.E. M6x14	VIS	SCREW	1
27	000 1111 06 6 3	RONDELLA elastica	RONDELLE elastique	CLIP	6
28	000 1356 01 3 3	VITE T.E. M6x18	VIS	SCREW	2
29	000 1354 01 3 3	VITE T.E. M6x14	VIS	SCREW	4
30	125 08 091 0 05	GUARNIZIONE	JOINT	GASKET	2
31	213 21 004 0 80	TUBO scarico destro	TUYAU d'échappement droit	RH exhaust tube	1
32	000 1454 01 3 3	VITE T.E. M8x20	VIS	SCREW	4
33	000 1101 08 4 3	RONDELLA piana	RONDELLE	WASHER	4
34	000 1111 08 6 3	RONDELLA elastica	RONDELLE elastique	CLIP	4
35	000 1101 08 4 3	RONDELLA piana	RONDELLE	WASHER	4
36	211 26 003 0 00	FASCETTA	COLLIER	CLAMP	1
37	000 1354 01 3 3	VITE T.E. M6x14	VIS	SCREW	1
38	000 1125 09 0 0	RONDELLA piana	RONDELLE	WASHER	1
39	000 1111 06 6 3	RONDELLA elastica	RONDELLE elastique	CLIP	1
40	000 1013 06 2 3	DADO	ECROU	NUT	1

FIG.	ORD. N°	DESCRIZIONE	DESCRIPTION	DESCRIPTION	QT.
41	213 21 005 0 80	TUBO scarico sin.	TUYAU d'échappement gauche	LH exhaust tube	1
42	125 08 009 3 00	GHIERA	ANEAU fileté	SLEEVE	2
43	213 21 006 0 00	SILENZIATORE destro	SILENCIEU droit	RH silencer	1
44	211 20 015 0 80	COPRICATENA	COUVRE - CHAINE	CHAIN cover	1
45	000 1101 06 4 3	RONDELLA piana	RONDELLE	VASHER	1
46	000 1111 06 6 3	RONDELLA elastica	RONDELLE elastique	CLIP	1
47	000 1351 01 3 3	VITE T.E. M6X8	VIS	SCREW	1
48	213 21 007 0 00	SILENZIATORE sinistro	SILENCIEU GAUCHE	LH silencer	1
49	136 19 630 0 0C	TAMPONE	TAMPON	PAD	1
50	211 21 016 0 80	SCATOLA attrezzi sin. completa dei part.51/52/53	BOITE gauche avec fig. 51/52/53	LH BOX with fig. 51/52/53	1
51	213 21 016 0 02	COPERCHIO scatola sin.	COUVERCLE boite gauche	LH BOX cover	1
52	136 19 865 5 00	POMOLO	BOULON	BOLT	2
53	211 21 016 0 01	FONDO scatola sin.	BOITE gauche	LH BOX	1
54	000 1354 01 3 3	VITE T.E. M6 x 14	VIS	SCREW	6
55	000 1111 06 6 3	RONDELLA elastica	RONDELLE elastique	CLIP	6
56	000 1101 06 4 3	RONDELLA piana	RONDELLE	WASHER	6
57	000 1013 06 2 3	DADO	ECROU	NUT	6
58	211 21 009 0 80	SCATOLA attrezzi destra completa dei part.52/59/60	BOITE droit avec fig. 52/59/60	RH BOX with fig.52/59/60	1
59	213 21 009 0 01	FONDO scatola destra	BOITE droit	RH BOX	1
60	213 21 009 0 02	COPERCHIO scatola destra	COUVERCLE boite droit	RH BOX cover	1

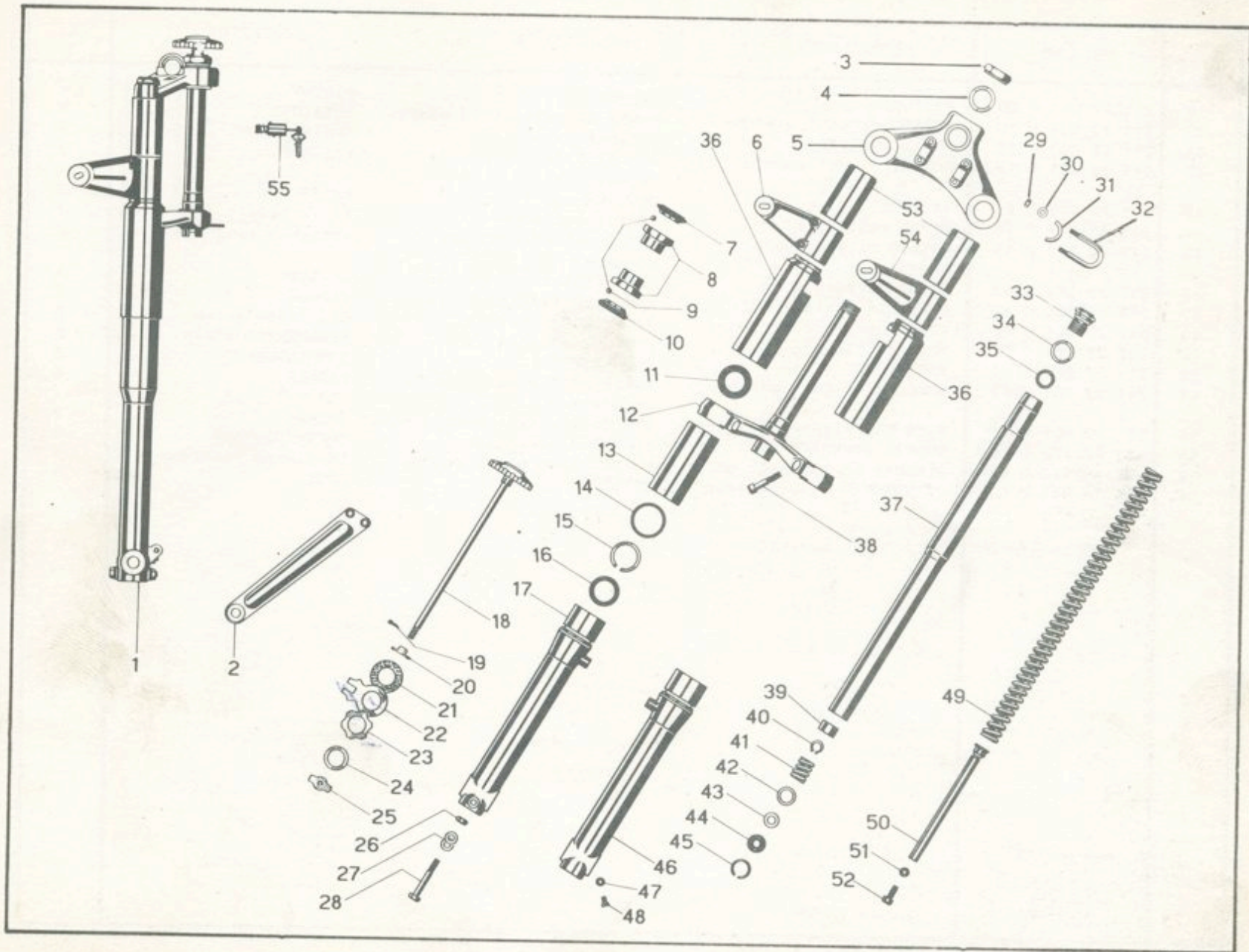

FIG.	ORD. N°	DESCRIZIONE	DESCRIPTION	DESCRIPTION	QT.
1	213 22 100 0 00	FORCELLA telescopica comp.	FOURCHE télescopique comp.	TELESCOPIC fork	1
2	211 24 006 0 80	PERMO flangia	ARRET de la bride	FLANGE stop	1
3	211 22 001 0 36	DADO centrale	ECROU central	NUT	1
4	211 22 001 0 37	RONDELLA	RONDELLE	WASHER	1
5	211 22 001 0 27	TESTA forcella	TETE de la bride	FORK head	1
6	136 19 940 0 01	FLANGIA porta fanale ds.	BRIDE porte phare droite	RH flange headlamp	1
7	116 00 106 0 00	SEMICALOTTA sup.	DEMI-CHAPEAU superieur	UPPER half sleeve	1
8	116 00 105 0 00	CALOTTA sede sfere	CHAPEAU siège billes	BALS seat	2
9	000 6397 05 1 0	SPERA 3/16"	BILLE	BALL	52
10	116 00 107 0 00	SEMICALOTTA inf.	DEMI-TASSE inferieure	LOWER half sleeve	1
11	211 22 001 0 24	ANELLO elast. fodero sup.	CIRCLIP fourreau superieur	UPPER ring	2
12	213 22 100 0 04	BASE forcella	BASE de la fourche	FORK basement	1
13	211 22 001 0 21	PODERO inferiore	FOURREAU inferieur	LOWER housing	2
14	211 22 001 0 20	GUARNIZIONE per fodero inf.	JOINT pour fourreau inf.	GASKET	2
15	211 22 001 0 19	ANELLO ritegno guarnizione	BAGUE de retien du joint	RING	2
16	211 22 001 0 18	GUARNIZIONE aste	JOINT des tiges	GASKET	2
17	211 22 001 0 01	TUBO scorrevole ds.	TUBE coulissant droit	RH tube	1
18	211 22 001 0 38	POMOLO con tirante	POMMEAU	STEERING cont. kinob	1
19	211 22 001 0 35	COPIGLIA	GOUPILLE	COTTER pin	1
20	211 22 001 0 39	MOLLETTA frenasterzo	RESSORT du frein de direct.	SPRING	1
21	211 22 001 0 31	RONDELLA fibra frenast.	RONDELLE en du frein direct.	FIBRE washer	1
22	211 22 002 0 00	ELEMENTO frenasterzo	ENSEMBLE du frein de direct.	STOP plate	1
23	211 22 001 0 32	RONDELLA frenasterzo	RONDELLE elastique du frein de direction	CLIP	1
24	211 22 001 0 33	APPOGGIO rondelle elast.	APPUI de la rondelle elastique	WASHER seat	1
25	211 22 001 0 34	RITEGNO frenasterzo	RETIENT du frein de direct.	RETAINER	1
26	211 22 001 0 05	DADO	ECROU	WELL hinge	1
27	211 22 001 0 04	RONDELLA piana	RONDELLE	WASHER	2
28	211 22 001 0 03	VITE serraggio	VIS de serrage	SCREW	1
29	211 22 001 0 43	DADO	ECROU	UBOLT NUT	4
30	211 22 001 0 42	RONDELLA piana	RONDELLE	WASHER	4
31	211 22 001 0 41	SEMIANELLO	DEMI-BAGUE	HALP-RING	2
32	211 22 001 0 40	CAVALLOTTO	JONCTION	"U" BOLT	2
33	211 22 011 0 00	TAPPO laterale	BOUCHON	PUG	2
34	211 22 001 0 29	RONDELLA per tappo	RONDELLE du bouchon	WASHER	2
35	211 22 001 0 30	GUARNIZIONE per tappo	JOINT du bouchon	GASKET	2
36	213 22 100 0 01	PODERO inferiore	FOURREAU inferieur	LOWER housing	2
37	213 22 100 0 03	ASTA di forza	TIGE de force	TUBE	2
38	211 22 001 0 26	VITE morsetto	VIS de la tige	SCREW	2

FIG.	ORD. N°	DESCRIZIONE	DESCRIPTION	DESCRIPTION	QT.
39	211 22 001 0 09	PISTONE	PISTON	PISTON	2
40	211 22 001 0 10	ANELLO ritegno pistone	BAGUE de retient du piston	RETAINER	2
41	211 22 001 0 11	MOLLA rimbalzo	RESSORT	SPRING	2
42	211 22 001 0 12	RONDELLA spallamento	RONDELLE de réglage de la soupape	WASHER	2
43	211 22 001 0 13	VA'VOLA	SOUPAPE	VALVE	2
44	211 22 001 0 14	CORPO valvole	CORP de soupape	VALVE body	2
45	211 22 001 0 15	ANELLO ritegno corpo valvola	BAGUE de retenue corp soupape	RETAINER ring	2
46	211 22 001 0 02	TUBO scorrevole sn.	TUBE coulissant gauche	LH tube	1
47	211 22 001 0 45	RONDELLA scarico olio	RONDELLE vidange huile	WASHER	2
48	211 22 001 0 44	VITE scarico olio	VIS vidange huile	OIL drain screw	2
49	211 22 001 0 07	MOLLA molleggio	RESSORT suspension	FEATHERING screw	2
50	211 22 001 0 08	VARIATORE	REGULATEUR	REGULATOR	2
51	211 22 001 0 17	RONDELLA tenuta variatore	RONDELLE d'etancheité du regulateur	WASHER	2
52	211 22 001 0 16	VITE bloccaggio variatore	VIS de blocage du regulateur	SCREW	2
53	213 22 100 0 02	FODERO superiore	POURREAU superieur	UPPER housing	2
54	136 19 940 0 02	FLANGIA portafanale sn.	BRIDE porte phare gauche	LH flange headlamp	1
55	136 19 941 0 02	CATENACCIO bloccasterzo	SERRURE	LOCK	1

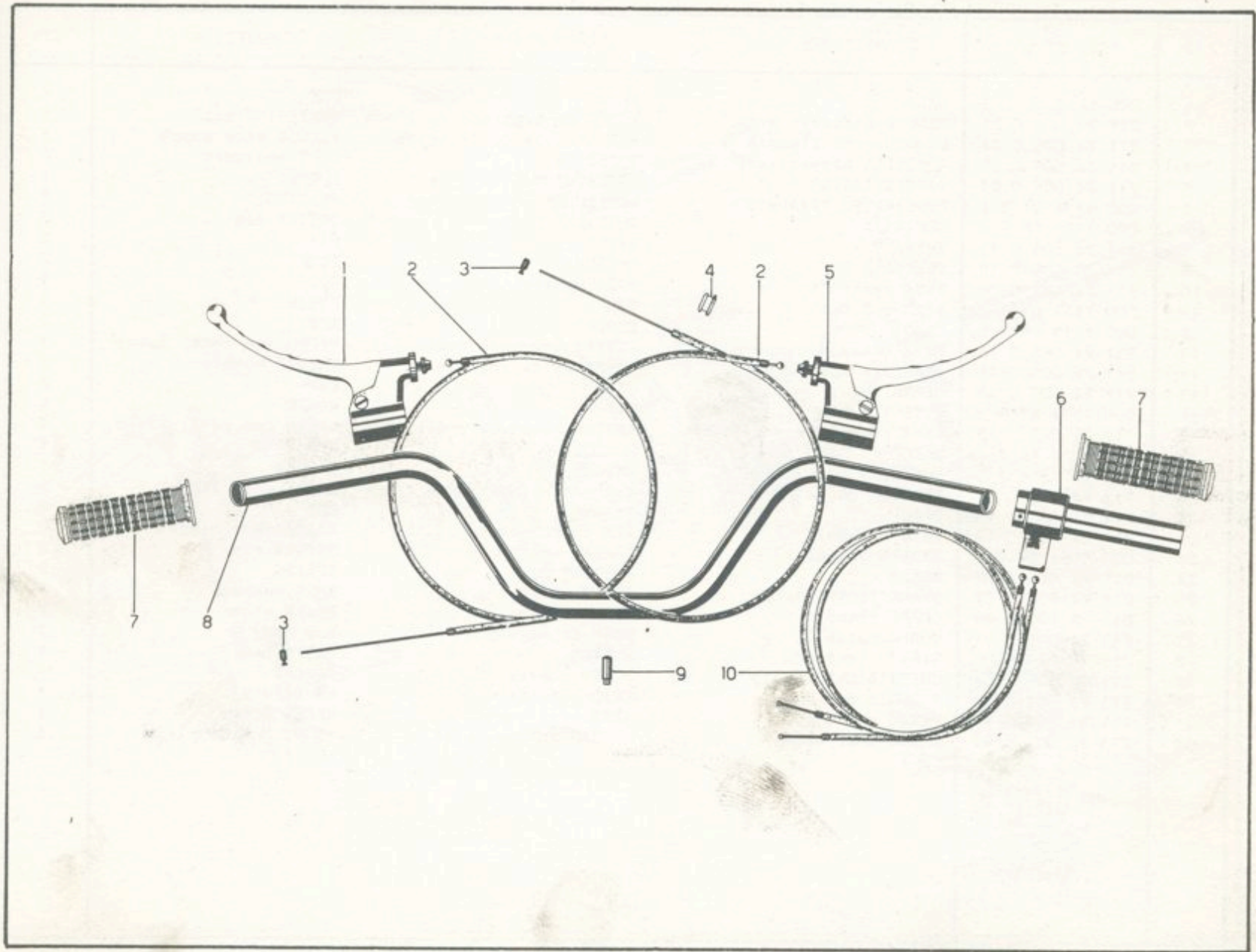

FIG.	ORD. N°	DESCRIZIONE	DESCRIPTION	DESCRIPTION	QT.
1	213 23 101 0 00	GRUPPO leva frizione	GROUPE levier embrayage	GROUP clutch lever	1
2	211 23 006 0 00	CAVO frizione freno ant.	CABLE embrayage et frein anterior	CLUTCH cable and front brake	2
3	211 23 008 0 00	MORSETTO	ETAN	HOLDFAST	2
4	000 5407 00 0 0	PASSAFILO	PASSE-cable	FAIRLEAD	1
5	213 23 102 0 00	GRUPPO leva freno	GROUPE levier frein	GROUP brake lever	1
6	211 23 002 0 00	COMANDO gas	COMMANDE gaz	THROTTLE control	1
7	213 23 103 0 00	MANOPOLA gomma	POIGNEE en caoutchouc	RUBBER grip	2
8	213 23 100 0 00	MANUBRIO	GUIDON	HANDLEBAR	1
9	211 22 004 0 00	GRANO fermo manubrio	AXE pour guidon	HANDLEBAR pin	1
10	136 19 755 0 00	CAVO gas	CABLE de gaz	THROTTLE cable	2

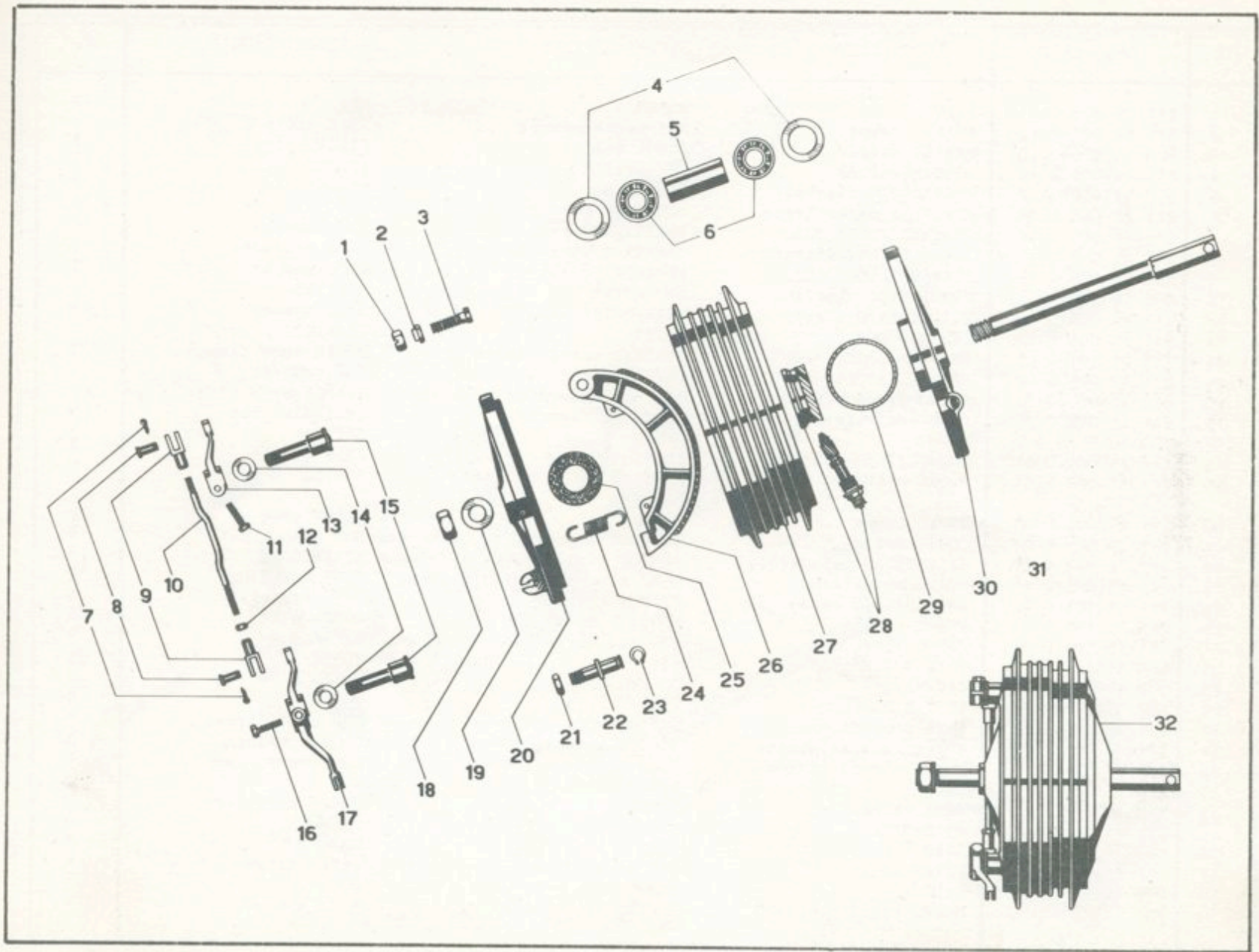

FIG.	ORD. N°	DESCRIZIONE	DESCRIPTION	DESCRIPTION	CT.
1	000 1019 10 2 3	DADO	ECROU	NUT	1
2	211 24 005 0 21	DADO centraggio asta	ECROU de centrage de l'axe	CENTERING nut	1
3	211 24 005 0 22	PERNO fermo flangia	AXE blocage de la bride	FLANGE stop hinge	1
4	211 24 005 0 05	RONDELLA tarapolvere	RONDELLE	DUST excluder	2
5	211 24 005 0 04	DISTANZIATORE	ENTRETOISE	SPACER	1
6	000 5734 01 1 2	CUSCINETTO 17x40x12	ROULEMENT	BEARING	2
7	000 1131 18 2 0	COPIGLIA	GOUPILLE	COTTER pin	2
8	211 24 005 0 19	SPINA	AXE	PIN	2
9	211 24 005 0 18	FORCELLA	FOURCHE	FORK	2
10	213 24 007 0 01	ASTA centrale	TIGE central	ROD	1
11	000 1361 01 3 3	VITE T.E.M6x30	VIS	SCREW	1
12	000 1011 06 2 6	DADO	ECROU	NUT	1
13	211 24 005 0 16	LEVA comando camma sup.	LEVIER commande camme sup.	UPPER cam cont. lever	1
14	211 24 005 0 11	RONDELLA spallamento	RONDELLE de réglage	THRUST washer	2
15	211 24 005 0 10	CAMMA	CAME	CAM	2
16	000 1354 01 3 3	VITE T.E.M6x25	VIS	SCREW	1
17	211 24 005 0 15	LEVA comando camma inf.	LEVIER commande came inf.	LOWER cam cont. lever	1
18	000 1014 16 2 3	DADO	ECROU	NUT	1
19	000 1101 16 4 3	RONDELLA	RONDELLE	WASHER	1
20	213 24 007 0 02	FLANGIA porta ceppi	PLATEAU porte sabots	BRAKE shoe lange	1
21	211 24 005 0 13	DADO	ECROU	NUT	2
22	211 24 005 0 12	FULCRO ceppi	AXE porte sabots	BRAKE shoe hinge	2
23	000 5064 09 0 0	ANELLO Seeger	ANNEAU seeger	SEEGER ring	2
24	211 24 005 0 09	MOLLA	RESSORT	SPRING	2
25	211 24 005 0 07	GUARNIZIONE feltro	JOINT en feutre	FELT washer	1
26	211 24 005 0 08	CEPPO freno	SABOT du frein	BRAKE shoe	2
27	211 24 005 0 01	CORPO mozzo	CORP du moyeau	HJB body	1
28	211 30 023 0 00	RINVIO contaKm.	RENVY	DRIVE pad	1
29	213 24 007 0 03	GUARNIZIONE rinvio	JOINT renvoy	GASKET	1
30	213 24 007 0 04	FLANGIA ds.	BRIDE droite	RH flange	1
31	211 24 005 0 14	PERNO ruota	AXE de la roue	WHEEL ginge	1
32	213 24 007 0 80	MOZZO ant. comp.	MOYEAU ant. complet	FRONT hub complete	1

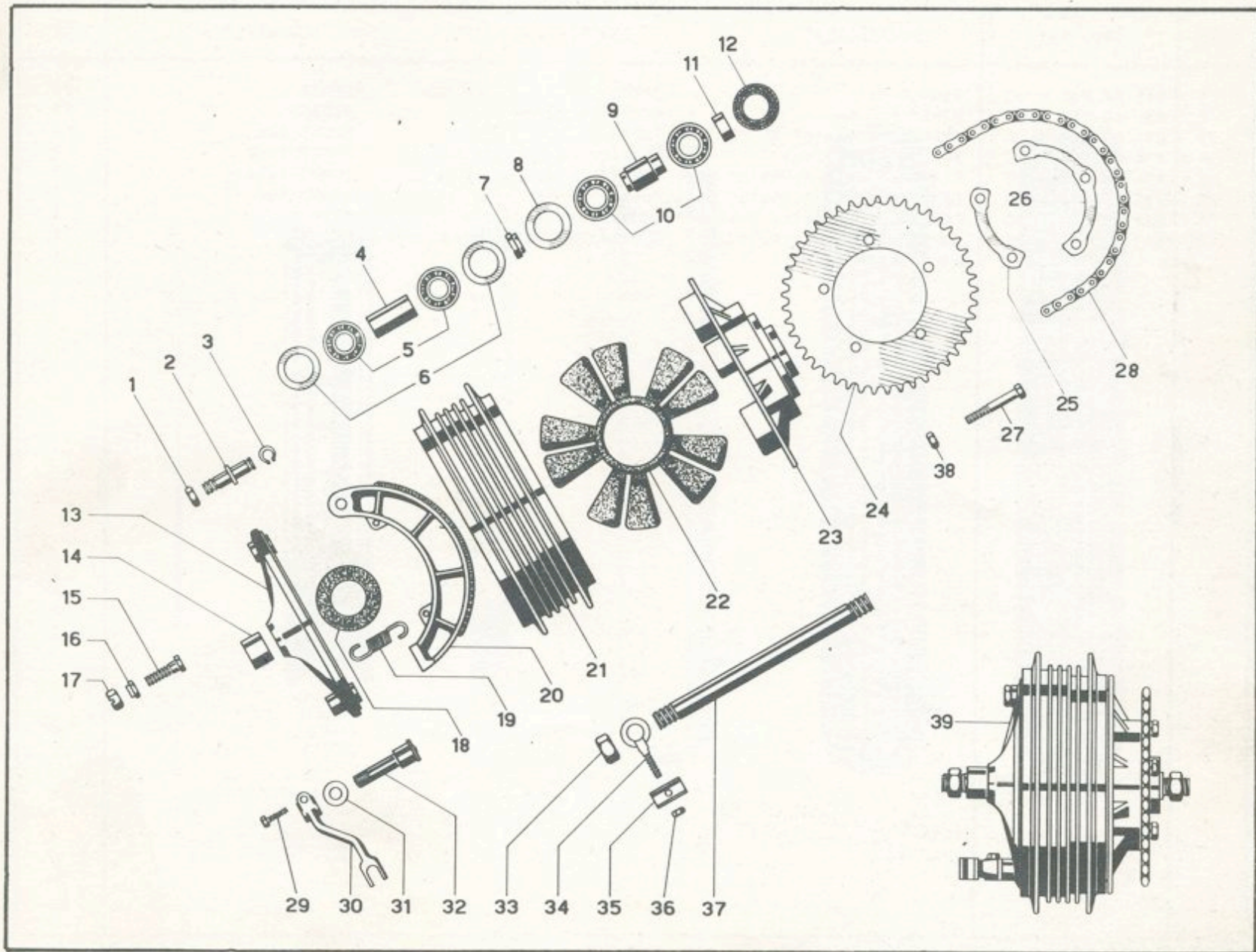

FIG.	ORD. N°	DESCRIZIONE	DESCRIPTION	DESCRIPTION	QT.
1	211 25 005 0 11	DADO	ECROU	NUT	2
2	211 25 005 0 10	FULCRO ceppi	AXE porte sabots	SHOE hinge	2
3	000 5064 09 0 0	ANELLO seeger	BAGUE seeger	SEEGER ring	2
4	211 25 005 0 14	DISTANZIATORE	ENTRETOISE	SPACER	1
5	000 5734 01 1 2	CUSCINETTO 17x40x12	ROULEMENT	BEARING	2
6	211 25 005 0 13	RONDELLA parapolvere	RONDELLE pare-poussiere	DUST excluder	1
7	211 25 005 0 16	DISTANZIATORE est.	ENTRETOISE ext.	EXT. spacer	1
8	211 25 005 0 17	RONDELLA parapolvere	RONDELLE pare-poussiere	DUST excluder	1
9	211 25 005 0 18	DISTANZIATORE int.	ENTRETOISE int.	INT. spacer	1
10	000 5693 01 1 2	CUSCINETTO 20x42x12	ROULEMENT	BEARING	2
11	211 25 005 0 19	DISTANZIATORE est.	ENTRETOISE ext.	EXT. spacer	1
12	211 25 005 0 20	GUARNIZIONE	JOINT	GASKET	1
13	213 25 101 0 01	FLANGIA porta ceppi	PLATEAU porte sabots	BRAKE shoe flange	1
14	211 25 005 0 02	DISTANZIATORE est.	ENTRETOISE ext.	EXT. spacer	1
15	211 25 005 0 24	PERNO fermo flangia	AXE de blocage de la bride	FLANGE stop hinge	1
16	211 25 005 0 25	DADO centraggio asta	ECROU de centrage	CENTERING nut	1
17	000 1019 10 2 3	DADO	ECROU	NUT	1
18	211 25 005 0 04	GUARNIZIONE feltro	JOINT feutre	FELT gasket	1
19	211 25 005 0 06	MOLLA richiamo ceppi	RESSORT de rappel des sabots	SPRING	1
20	211 25 005 0 05	CEPPO freno	SABOT	BRAKE shoe	2
21	211 25 005 0 01	CORPO mozzo	CORP du moyeau	HUB body	1
22	211 25 003 0 00	SILENTBLOC parastrappi	TAMPON accouplement elastique	SILENTBLOC	1
23	211 25 005 0 15	CORPO parastrappi	CORP accouplement elastique	PLEX coupling	1
24	211 25 101 0 02	INGRANAGGIO catena Z42	PIGNON caine	CAIN sprocket	1
25	213 25 101 0 03	FERMO vite	BLOCAGE de la vis	SCREW stop	1
26	213 25 101 0 04	FERMO vite	BLOCAGE de la vis	SCREW stop	1
27	000 1463 01 3 3	VITE T.E.M8x55	VIS	SCREW	5
28	000 4500 21 0 0	CATENA	CHAINE	CHAIN	1
29	000 1357 01 3 3	VITE T.E.M6x20	VIS	SCREW	1
30	211 25 005 0 09	LEVA comando camme	LEVIER commande came	CAM cont. lever	1
31	211 25 005 0 08	RONDELLA spallamento	RONDELLE de réglage	THRUST washer	1
32	211 25 005 0 07	CAMMA comando ceppi	CAME commande sabots	SHOE cont. cam	1
33	000 1014 16 2 3	DADO	ECROU	NUT	2
34	146 41 394 0 00	TENDICATENA	TENDEUR de la chaine	CHAIN stretcher	2
35	211 25 007 0 00	PIASTRINA	PLAQUETTE	PLATE	2
36	000 1013 06 2 3	DADO	ECROU	NUT	4
37	211 25 005 0 12	PERNO ruota	AXE de la roue	WHEEL hinge	1
38	000 1011 08 4 3	DADO	ECROU	NUT	5
39	213 25 101 0 80	MOZZO post. completo	MOYEAU ar. complet	REAR hub	1

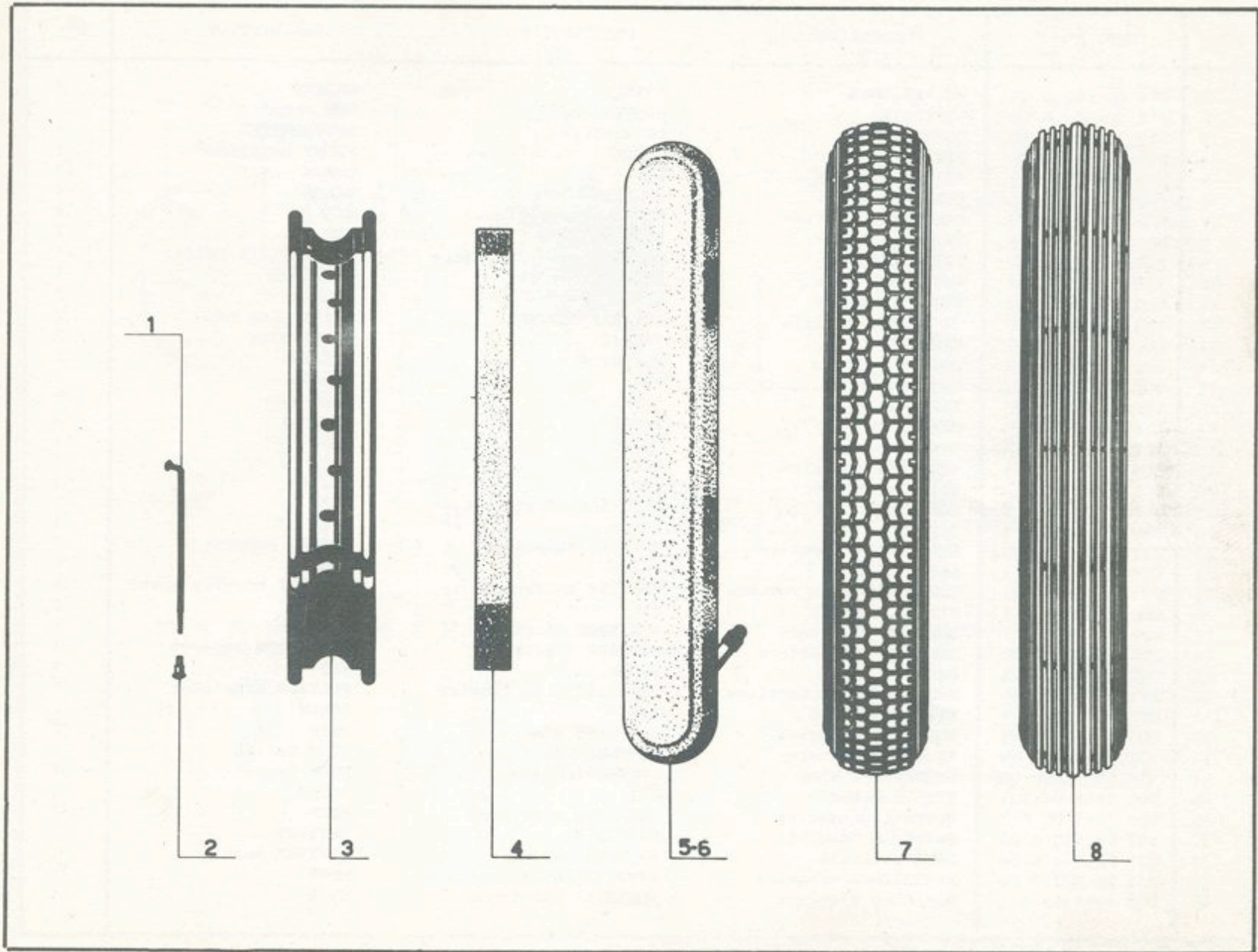

FIG.	ORD. N°	DESCRIZIONE	DESCRIPTION	DESCRIPTION	QT.
1	213 24 008 0 00	RAGGIO 3x150	RAYON	SPOKE	72
2	136 19 723 0 00	NIPLO	ECROU de rayon	NIPLES	72
3	211 25 002 0 00	CERCHIO 1,85x18" AS	JANTE	FRONT rin	2
4	136 19 725 0 00	FASCIA protezione	COLLIER de protection	PROTECTION	2
5	136 19 726 0 00	CAMERA d'aria 2,75x18" ant.	CHAMBRE à air av.	FRONT tube	1
6	211 25 010 0 00	CAMERA d'aria 3,25x18" post.	CHAMBRE à air ar.	REAR tube	1
7	213 25 004 0 00	COPERTURA scolpita 3,25x18"	COUVERTURE sculptée	TYRE	1
8	213 24 002 0 00	COPERTURA rigata 2,75x18" rinforzata	COUVERTURE rayée renforcée	TYRE	1

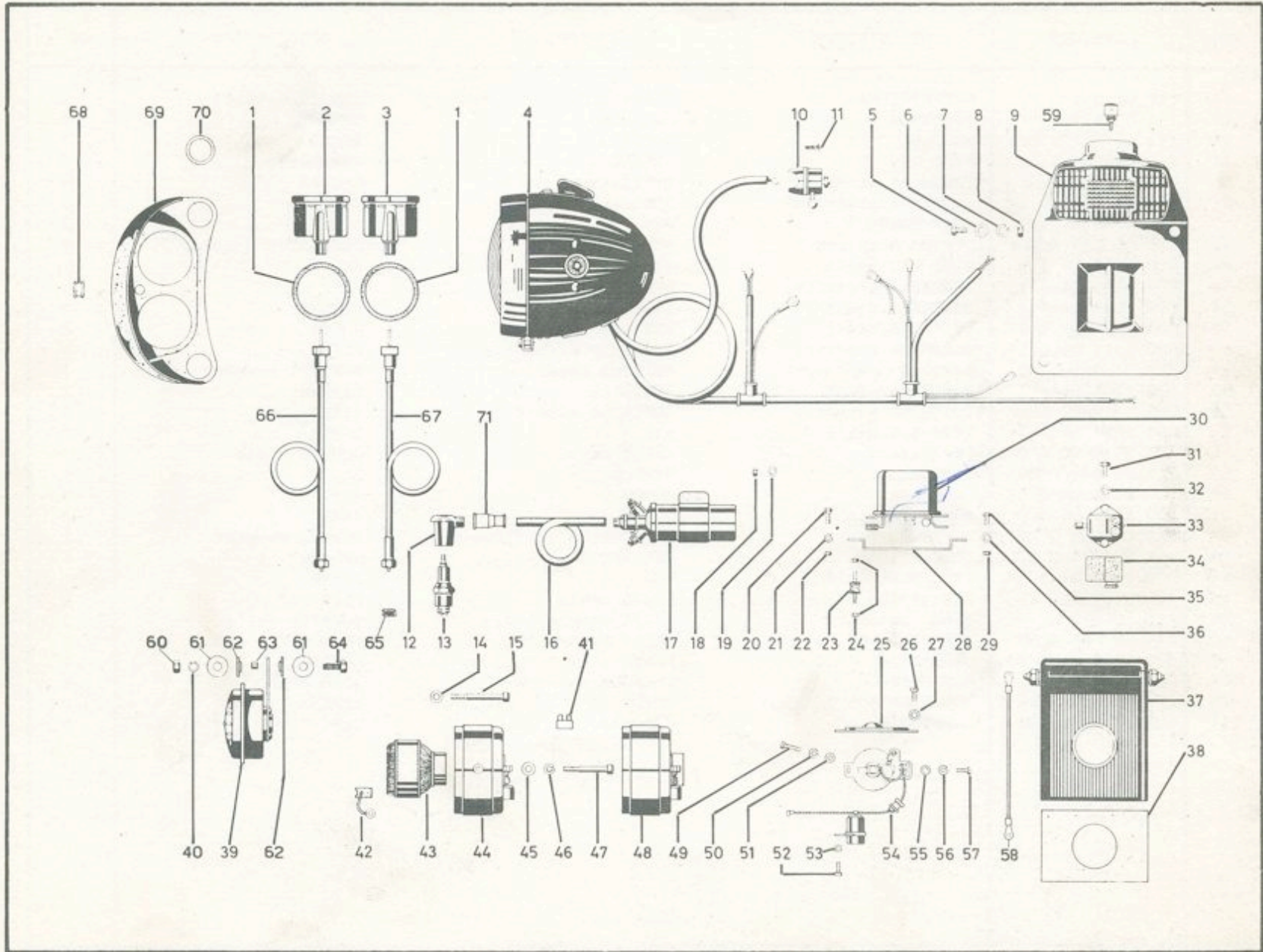

FIG.	ORD. N°	DESCRIZIONE	DESCRIPTION	DESCRIPTION	QT.
1	211 26 022 0 01	GUARNIZIONE	JOINT	GASKET	2
2	211 30 011 0 00	CONTAGIRI	COMPTE tours	RPM counter	1
3	213 30 009 0 00	CONTAKM.	TACHIMETRE	SPEEDOMETER	1
4	211 26 001 0 00	FANALE ant.	PHARE	FRONT headlamp	1
5	000 1354 01 3 3	VITE T.E.M6x14	VIS	SCREW	4
6	000 1101 06 4 3	RONDELLA piana	RONDELLE	WASHER	4
7	000 1111 06 6 3	RONDELLA elastica	RONDELLE elastique	CLIP	4
8	000 1013 06 2 3	DADO	ECROU	NUT	4
9	211 26 002 0 00	PORTATARGA	PORTE plaque de police	NUMBERPLATE holder	1
10	136 19 635 0 02	DEVIATORE luce	DEVIATEUR code	SELECTOR	1
11	000 2657 01 1 3	VITE T.C.M4x14	VIS	SCREW	2
12	154 59 100 1 00	CAPPUCCIO candela	CHAPEAU bougie	SPARK plug cap	2
13	000 4507 09 0 0	CANDELA	BOUGIE	SPARK plug	2
14	000 1101 06 4 3	RONDELLA piana	RONDELLE	WASHER	2
15	000 2167 01 3 3	VITE M6x70	VIS	SCREW	2
16	172 84 113 0 00	FILO candela	CABLE bougie	WIRE	2
17	211 26 010 0 00	BOBINA AT	BOBINE HT	AC coil	2
18	000 1011 05 2 3	DADO	ECROU	NUT	4
19	000 1111 05 6 3	RONDELLA elastica	RONDELLE elastique	CLIP	4
20	000 1304 01 1 3	VITE T.E.M5x14	VIS	SCREW	1
21	000 1111 05 6 3	RONDELLA elastica	RONDELLE elastique	CLIP	1
22	000 1011 04 2 3	DADO	ECROU	NUT	1
23	211 26 017 0 00	SUPPORTINO elastico	SUPPORT elastique	RUBBER support	3
24	000 1011 04 2 3	DADO	ECROU	NUT	6
25	211 02 015 0 00	COPERCHIO vano rottore	CHAPEAU du rupteur	CONTACT breaker cover	1
26	000 2705 01 1 3	VITE T.C.M5x12	VIS	SCREW	2
27	000 1111 05 6 3	RONDELLA elastica	RONDELLE elastique	CLIP	2
28	211 26 016 0 00	SUPPORTO regolatore	SUPPORT régulateur	REGULATOR support	1
29	000 1011 04 2 3	DADO	ECROU	NUT	1
30	211 26 015 0 00	REGOLATORE di tensione	REGULATEUR de tension	VOLTAGE regulator	1
31	000 1302 01 1 3	VITE T.E.M5x10	VIS	SCREW	2
32	000 1111 05 6 3	RONDELLA elastica	RONDELLE elastique	CLIP	2
33	172 84 717 0 00	INTERRUTTORE stop	INTERUPTEUR stop	STOP switch	1
34	136 19 710 0 00	PROTEZIONE stop	PROTECTION stop	STOP protection	1
35	000 1302 01 1 3	VITE T.E.M5x10	VIS	SCREW	1
36	000 1111 05 6 3	RONDELLA elastica	RONDELLE elastique	CLIP	1
37	157 64 460 0 00	BATTERIA 16AH 6V	BATTERIE	BATTERY	1
38	211 26 004 0 00	BASE batteria	BASE batterie	BATTERY base	1
39	211 26 027 0 00	AVVISATORE acustico	AVERTISSEUR acoustique	HORN	1
40	000 1111 06 6 3	RONDELLA elastica	RONDELLE elastique	CLIP	1

FIG.	ORD. N°	DESCRIZIONE	DESCRIPTION	DESCRIPTION	QT.
41	211 04 051 0 00	MORSETTIERA	PLAQUETTE de deriv.	JUNCTION box	1
42	211 03 021 0 01	SPAZZOLA	CHARBONS	BRUSHES	2
43	211 03 021 0 02	ROTORE	ROTOR	ROTOR	1
44	211 03 021 0 00	STATORE	DYNAMO	GENERATOR	1
45	211 03 022 0 00	RONDELLA piana	RONDELLE	WASHER	1
46	000 1111 06 6 3	RONDELLA elastica	RONDELLE elastique	CLIP	1
47	000 2163 01 3 3	VITE M6x50	VIS	SCREW	1
48	211 03 021 0 80	DINAMO composta	DYNAMO compl.	GENERATOR compete	1
49	000 2659 02 1 3	VITE T.C.M4x20	VIS	SCREW	1
50	000 1109 04 6 7	RONDELLA elastica	RONDELLE elastique	CLIP	1
51	000 1101 04 4 3	RONDELLA piana	RONDELLE	WASHER	1
52	000 2656 01 1 3	VITE T.C.M4x12	VIS	SCREW	1
53	000 1111 04 6 3	RONDELLA elastica	RONDELLE elastique	CLIP	1
54	211 04 035 0 00	RUTTORE completo	RUPTEUR compl.	CONTACT breaker compl.	1
55	000 1101 04 4 3	RONDELLA piana	RONDELLE	WASHER	2
56	000 1111 04 6 3	RONDELLA elastica	RONDELLE elastique	CLIP	2
57	000 2656 01 1 3	VITE T.C.M4x12	VIS	SCREW	2
58	000 5530 00 0 0	CAVO massa	CABLE masse	GROUND cable	1
59	211 26 025 0 00	TAMPONE	TAMPON	PAD	1
60	000 1013 06 2 3	DADO	ECROU	NUT	1
61	000 1106 06 4 3	RONDELLA piana	RONDELLE	WASHER	2
62	179 10 002 0 00	SUPPORTO gomma	SUPPORT en caoutchouc	RUBBER support	2
63	211 26 028 0 00	DISTANZIALE	ENTRETOISE	SPACER	1
64	000 1358 01 3 3	VITE T.E.M6x22	VIS	SCREW	1
65	000 5407 00 0 0	PASSAFILO	PASSE cable	FAIRLEAD	1
66	211 30 010 0 00	FUNE contagiri	CABLE compte-tours	COUNTER cable	1
67	211 30 024 0 00	FUNE contaKm.	CABLE tachymètre	TACHOMETER cable	1
68	000 5401 01 0 0	PASSAFILO	PASSE cable	FAIRLEAD	1
69	211 30 020 0 00	CRUSCOTTO	PLANCHE de bord	DASH BOARD	1
70	211 22 001 0 29	RONDELLA sotto tappo	RONDELLE	WASHER	2
71	199 08 033 0 02	CAPPUCCIO	CHAPEAU	CAP	2

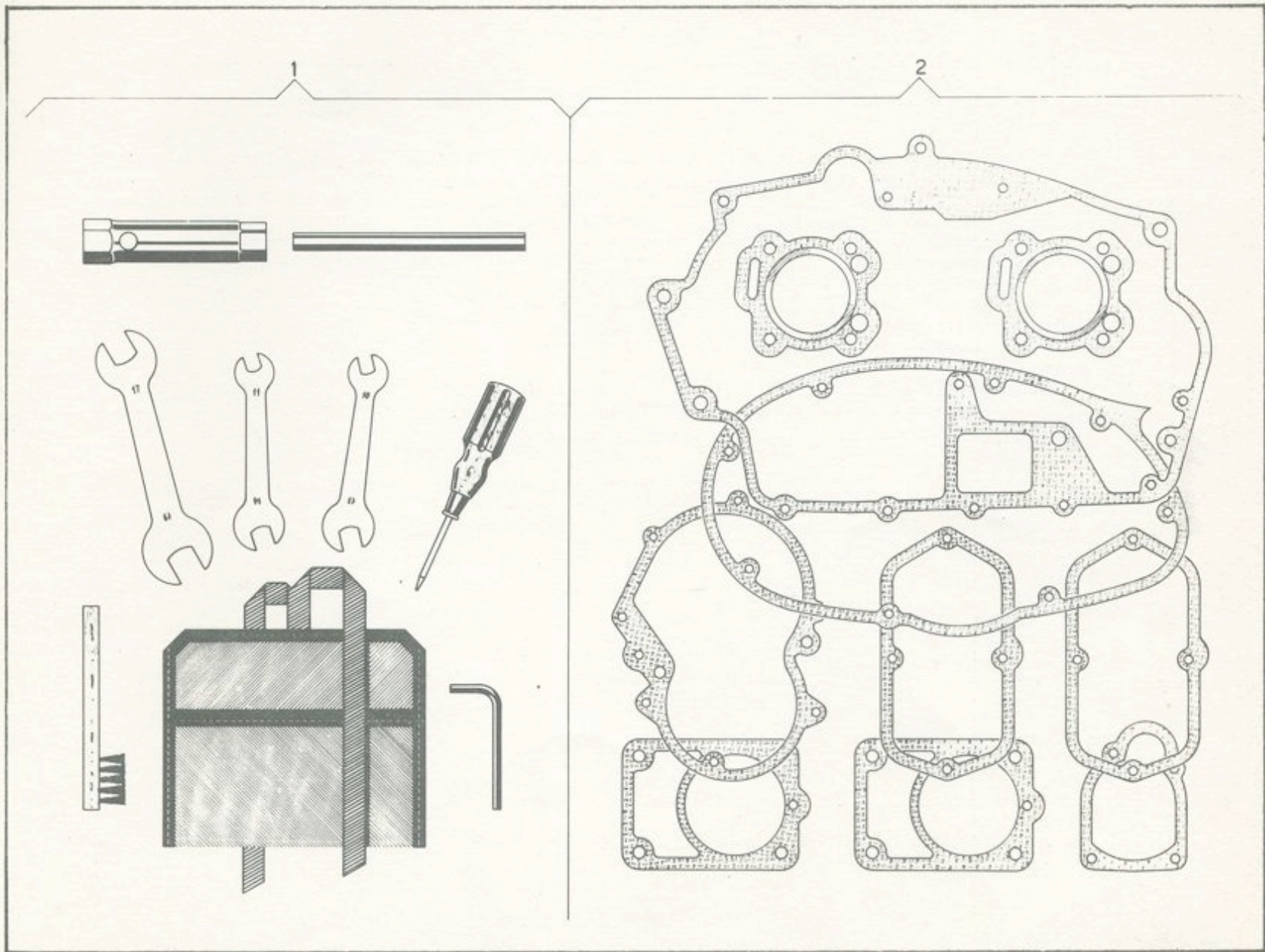

FIG.	ORD. N°	DESCRIZIONE	DESCRIPTION	DESCRIPTION	QT.
1	211 27 000 0 80	SERIE ATTREZZI: BORSA CHIAVE fissa 17/18 CHIAVE fissa 10/13 CHIAVE fissa 11/14 CHIAVE esagonale 5 CHIAVE a tubo 21/14 MANICO CACCIAVITE SPAZZOLINO	OUTILS EN DOTATION: TROUSSE à outils CLEF CLEF CLEF CLEF hexagonal CLEF à tube MANCHE TOURNEVIS BROSSE	TOOLS SET: TOOLS bag SPANNER SPANNER SPANNER HEXAGONAL spanner TUBE spanner HANDLE SCREW-DRIVER BRUSH	
2	213 02 007 0 80	SERIE GUARNIZIONI: CARTER COPERCHIO frizione COPERCHIO ingranaggi camme COPERCHIO selettore tra cilindro e carter tra cilindro e testa tra testa e cappello	SERIE DE JOINTS: CARTER COUVERCLE embrayage COUVERCLE pignon cames COUVERCLE sélecteur entre carter et cylindre entre cylindre et culasse entre culasse et chapeau	SET OF GASKETS: CRANCKASE CLUTCH cover CAJES gear cover SPEED change cover between cylinder and crankcase between cylinder and cylinder head between cylinder head and cover	