

CATALOGO PARTI RICAMBIO

CATALOGUE DES PIECES DE RECHANGE

SPARE PARTS CATALOGUE

**MV 250 B**



**CATALOGO PARTI RICAMBIO**

**CATALOGUE DES PIECES DE RECHANGE**

**SPARE PARTS CATALOGUE**

**MV 250 B**

**MECCANICA VERGHERA**

**STABILIMENTI: CASCINA COSTA - VERGHERA (GALLARATE)**

**TELEFONO 20.478 GALLARATE - TELEGRAMMI: EMMEVI (GALLARATE)**

**STABILIMENTI: CASCINA COSTA-VERGHERA (GALLARATE) (ITALY)**

**(ITALY)**

IMPORTANTE

Le ordinazioni per ciascun pezzo richiesto devono essere redate su apposito modulo con data, nome e indirizzo esatto del richiedente.

Dette ordinazioni devono essere indirizzate a:  
MECCANICA VERGHERA S.p.A. Cascina Costa - Gallarate (Varese). 21017

Telegrammi:  
EMMEVI - GALLARATE

Telex:  
31057 AGUSTA

Per ciascuna qualità dei pezzi desiderati, ogni ordinazione deve contenere le seguenti indicazioni:

- 1° - Il numero di ordinazione (II colonna)
- 2° - La prima parola della denominazione (III colonna) con eventuale indicazione di misura.
- 3° - Quantità pezzi richiesti (IV colonna).

Esempio di ordinazione per lettera:

Favorite al ns. indirizzo i seguenti pezzi di ricambio:  
161 70 1 26 4 00 Carter 1  
000 1354 01 1 3 Vite TE  
∅ 6Max14 10  
179 06 0 10 0 00 Pignone 3

Esempio ordinazione telegrafica

EMMEVI - GALLARATE  
Spedite: 16170126400 - 1  
00013540113 - 10  
17906010000 - 3

NOTE IMPORTANTE

Les commandes de pièces de rechange doivent nous être adressées sur des formulaires dans lesquels devront être clairement écrits le nom et l'adresse exacts du client.

Les commandes devront être adressées à:  
MECCANICA VERGHERA S.p.A.-21017  
CASCINA COSTA - Gallarate(Varese) Italie.  
Adresse télégraphique:EMMEVI-GALLARATE

Telex:  
31057 AGUSTA.

Dans chaque commande on devra préciser, pour chaque pièce désignée:

- 1° - Numero de commande (IIeme colonne)
- 2° - Le premier mot de la dénomination de la pièce avec l'indication éventuelle de la mesure (IIIeme colonne)
- 3° - Quantité des pièces commandées (IVeme colonne)

Exemple de commande par lettre: Veuillez nous envoyer les pièces suivantes:

161 70 1 26 400 Carter 1  
000 1354 01 13 Vis TE ∅ 6MA  
x14 10  
179 06 0 10 0 00 Pignon 3

Exemple de commande par telegramme

Envoyez:

16170126400 - 1  
0001354013 - 10  
17906010000 - 3

IMPORTANT

The orders for each requested item must be made by appropriate form with date, complete name and address of the buyer.

These orders must be forwarded to:

MECCANICA VERGHERA S.p.A. Cascina Costa - Gallarate (Varese)  
21017 ITALY  
Cables:  
EMMEVI - GALLARATE  
Telex: 31057 AGUSTA

For each type of item requested the order must be complete with the following indications:

- 1° - Purchase number (II column)
- 2° - First word of the nomenclature (III column) with indication
- 3° - Quantity of the items requested (IV column).

Example of order placed by letter:

Please forward to our address the following spare parts:

161 70 1 24 4 00 Case 1  
000 1354 01 1 3 Screw, dia  
6 MA x 14 10  
179 06 0 10 0 00 Pinion 3

Example of order placed by cable:

EMMEVI - GALLARATE

Please send:

16170126400 - 1  
00013540113 - 10  
17906010000 - 3

## INDICE

## TABLE DES MATIERES

## INDEX

TAB. N°	1	CARTER-POMPA OLIO	CARTER-POMPE HUILE	CASE GROUP-OIL PUMP
	2	BIELLA-PISTONE	BIELLE-PISTON	CONN. ROD-PISTON
	3	TESTA-CARBURATORE	CULASSE-CARBURATEUR	HEAD-CARBURATOR
	4	FRIZIONE-ALBERO PRIMARIO	EMBAYAGE-ARBRE PRIM.	CLUTCH-DRIVE SHAFT
	5	ALBERO SEC.-AVVIAMENTO	ARBRE SEC.-DEMARRAGE	DRIVEN SHAFT- STARTER
	6	SELETTORE	SELECTEUR	SELECTOR
	7	TELAIO-FORCELLONE-AMMORT.	CADRE-FOURCHE-AMORTISSEUR	FRAME-REAR FORKS
	8	PARAFANGHI -SERBATOIO SELLA- SILENZIATORE	GARDE BOUE- RESERVOIR SELLE - SILENCIEUX	MUD GUARD- TANK SADDLE- SILENCERS
	9	FORCELLA TELESCOPICA	FOURCHE TELESCOPIQUE	TELESCOPIC FORK GROUP
	10	MANUBRIO	GUIDON	HANDLEBAR
	11	MOZZO ANTERIORE	MOYEAU AV.	FRONT HUB. GROUP
	12	MOZZO POSTERIORE	MOYEAU AR.	HEAR HUB GROUP
	13	RUOTE E PNEUMATICI	ROUES ET PNEUMATIQUE	TYRES AND TUBES GROUP
	14	APPARECCHIATURE ELETTRICHE	INSTALLATION ELECTRIQUE	ELECT. INSTALLATION GROUP
	15	VARIE	VARIA	MISCELLANEOS

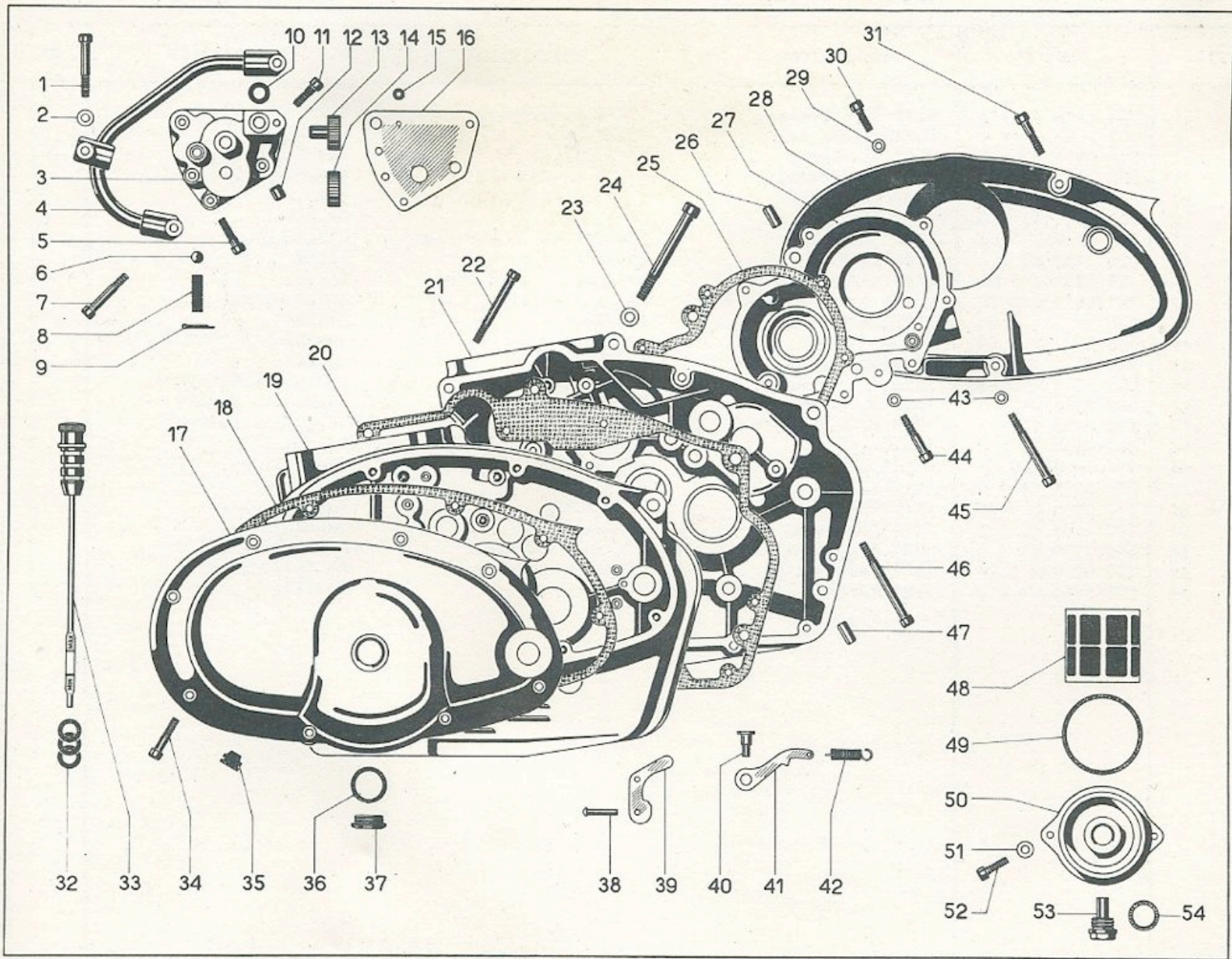
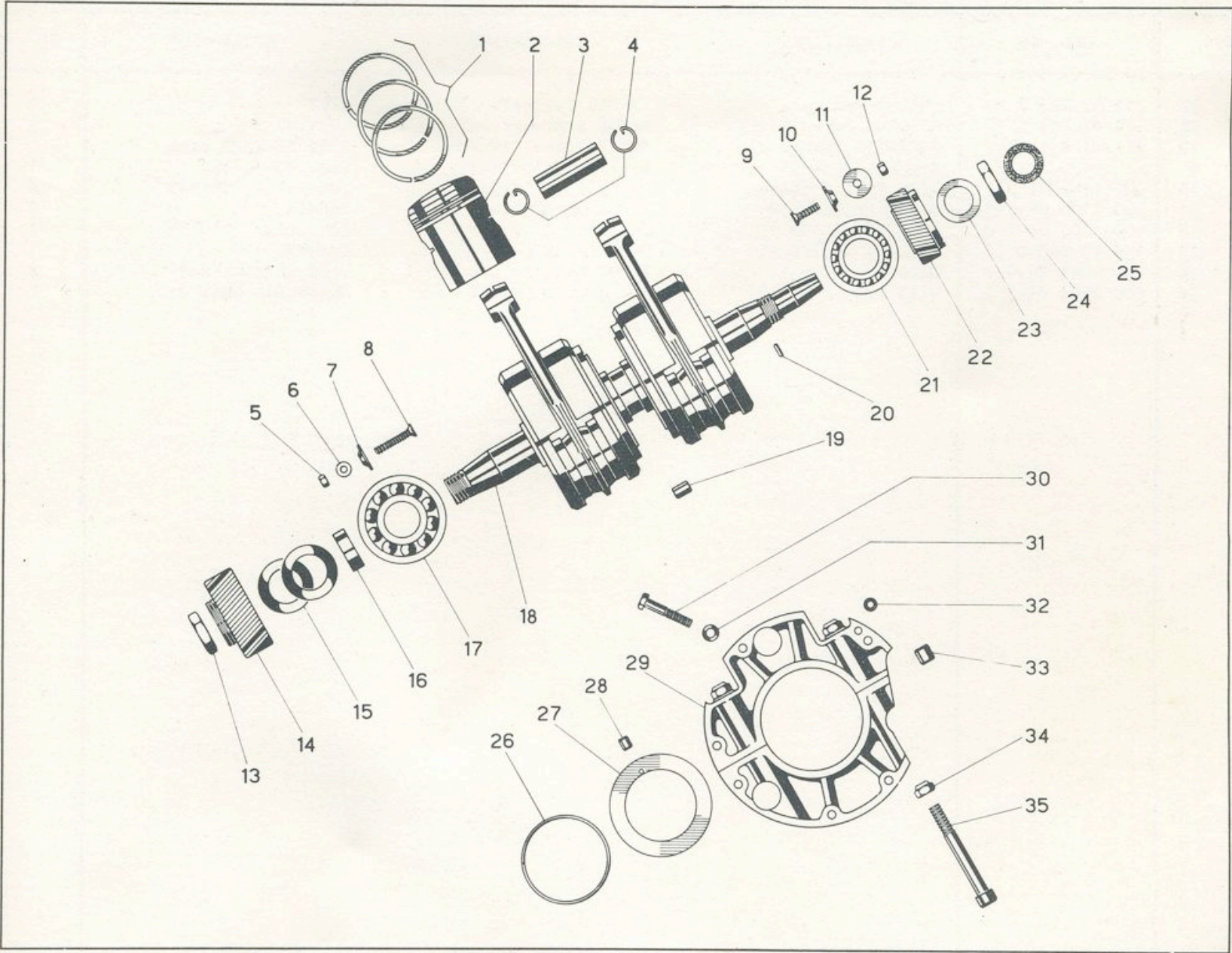

FIG.	ORD. N°	DESCRIZIONE	DESCRIPTION	DESCRIPTION	QT.
1	000 2162 01 3 3	VITE E.I. Ø6Max45	VIS E.I. Ø 6Max45	SCREW Dia.6MAX45	1
2	000 1101 06 4 3	RONDELLA Piana	RONDELLE	WASHER	3
3	211 06 003 0 00	CORPO Pompa	CORPS de Pompe	PUMP Housing	1
4	211 06 005 0 80	TUBO Aspirazione	TUYAU d'Admission	SUCTION Line	1
5	000 2158 01 3 3	VITE E.I. Ø6Max25	VIS E.I. Ø6MAX25	SCREW Dia.6MAX25	2
6	148 47 109 0 00	VALVOLA *	SOUPAPE *	VALVE *	1
	000 6397 11 1 0	SFERA 3/8 **	BIELLE 3/8 **	BALL 3/8 **	1
7	000 2160 01 3 3	VITE E.I. Ø6MAX35	VIS E.I. Ø6MAX35	SCREW Dia.6MAX35	2
8	148 47 110 0 00	MOLLA Valvola ***	RESSORT De Soupape***	VALVE Spring ***	1
	199 09 014 1 00	MOLLA Valvola ****	RESSORT De Soupape****	VALVE Spring ****	1
9	000 1131 18 2 0	COPIGLIA Ø1,8x20	GOUPILLE Ø 1,8x20	COTTER Pin Dia.1,8x20	1
10	000 5600 13 1 0	GUARNIZIONE OR	JOINT OR	"O" Ring	2
11	000 2156 01 3 3	VITE E.I. Ø6MAX20	VIS E.I. Ø6MAX20	SCREW Dia 6MAX20	2
12	132 14 038 0 00	BOCCOLA Centraggio	DOUILLE De Centrage	BUSHING	2
13	211 06 002 0 00	INGRAN. Condotto	ENGRENAGE Conduit	DRIVEN Gear	1
14	211 06 001 0 00	INGRAN. Conduttore	ENGRENAGE Conducteur	DRIVE Gear	1
15	000 5600 04 1 0	GUARNIZIONE OR	JOINT OR	"O" Ring	2
16	211 06 004 0 00	BASE Pompa	BASE De La Pompe	PUMP Basement	1
17	211 02 005 0 00	COPERCHIO Sinistro	COUVERCLE Gauche	LH Cover	1
18	211 02 006 0 00	GUARNIZIONE	JOINT	GASKET	1
19	211 02 002 0 80	CARTER Sinistro	CARTER Gauche	LH Case	1
20	211 02 004 0 00	GUARNIZIONE	JOINT	GASKET	1
21	211 02 003 0 00	CARTER Destro	CARTER Droit	RH Case	1
22	000 2165 01 3 3	VITE E.I. Ø6MAX60	VIS E.I. Ø6MAX60	SCREW Dia.6MAX60	7
23	000 1125 01 0 0	RONDELLA Piana	RONDELLE	WASHER	2
24	000 2265 01 3 3	VITE E.I. Ø8MAX80	VIS E.I. Ø8MAX80	SCREW Dia. 8MAX80	2
25	211 02 012 0 00	GUARNIZIONE	JOINT	GASKET	1
26	000 6398 10 0 0	RULLO	ERGOT	ROLLER	2
27	211 02 010 0 80	COPERCHIO Camme	COUVERCLE Cames	CAM Cover	1
28	211 02 020 0 00	COPERCHIO Destro	COUVERCLE Droit	RH Cover	1
29	000 1125 16 0 0	RONDELLA Piana	RONDELLE	WASHER	5
30	000 2156 01 3 3	VITE E.I. Ø6MAX20	VIS E.I. Ø6MAX20	SCREW Dia.6MAX20	5
	*	Fino al mot. 211010	Jusqu'au mot. 211010	Up To Engine 211010	
	**	Dal mot. 211011	A Partir du mot.211011	From Engine 211011	
	***	Fino al mot. 211010	Jusqu'au mot. 211010	Up To Engine 211010	
	****	Dal mot. 211011	A Partir du mot.211011	From engine 211011	

FIG.	ORD. N°	DESCRIZIONE	DESCRIPTION	DESCRIPTION	QT.
31	000 2159 01 3 3	VITE E.I. Ø6Max30	VIS E.I. Ø6Max30	SCREW Dia.6Max30	3
32	000 5600 17 1 0	GUARNIZIONE OR	JOINT OR	"O" Ring	3
33	211 06 010 0 80	ASTA Livello	TIGE Niveau	LEVEL Stick	1
34	000 2159 01 3 3	VITE E.I. Ø6Max30	VIS E.I. Ø6Max30	SCREW Dia.6Max30	8
35	139 22 030 0 00	CAPPUCCIO FILI	CHAPEAU De Protection	WIRE Cap	1
36	000 5605 03 0 0	GUARNIZIONE	JOINT	GASKET	1
37	122 05 059 1 00	TAPPO Frizione	BOUCHON de l'Embrayage	CLUTCH Plug	1
38	000 1133 07 2 8	RIBATTINO	RIVET	RIVET	2
39	125 08 200 0 00	PIASTRINA SALTAR.	PLAQUETTE De La Dent	PLATE	1
40	161 70 138 0 00	PERNO Levetta	AXE Du Levier	LEVER Hinge	1
41	136 19 367 0 00	LEVETTA	LEVIER	LEVER	1
42	136 19 152 0 00	MOLLA	RESSORT	SPRING	1
43	000 1125 16 0 0	RONDELLA Piana	RONDELLE	WASHER	2
44	000 2160 01 3 3	VITE E.I. Ø6Max35	VIS E.I. Ø6Max35	SCREW Dia.6Max35	1
45	000 2165 01 3 3	VITE E.I. Ø6Max60	VIS E.I. Ø6Max60	SCREW Dia.6Max60	1
46	000 2167 01 3 3	VITE E.I. Ø6Max70	VIS E.I. Ø6Max70	SCREW Dia.6Max70	1
47	000 6398 10 0 0	RULLO	ERGOT	ROLLER	2
48	171 82 104 0 80	FILTRO Olio	FILTRE Huile	OIL Filter	1
49	000 5607 44 1 0	GUARNIZIONE OR	JOINT OR	"O" Ring	1
50	211 06 006 0 00	COPERCHIO Filtro	COUVERCLE Du Filtre	FILTER Cover	1
51	000 1101 06 4 3	RONDELLA Piana	RONDELLE	WASHER	2
52	000 2156 01 3 3	VITE E.I. Ø6Max20	VIS E.I. Ø6Max20	SCREW Dia.6Max20	2
53	199 09 022 0 00	TAPPO Magnetico	BOUCHON Magnetique	MAGNETIC Plug	1
54	000 5605 02 0 0	GUARNIZIONE	JOINT	GASKET	1





F.G.	ORD. N°	DESCRIZIONE	DESCRIPTION	DESCRIPTION	QT.	
1	161 70 091 0 01	FASCIA Elastica AC Ø 53	SEGMENT De Piston	PISTON Ring	2	
	161 70 091 0 02	FASCIA Elastica ROS Ø 53	SEGMENT De Piston	PISTON Ring	2	
	161 70 091 0 03	FASCIA Elastica ROF Ø 53	SEGMENT De Piston	PISTON Ring	2	
	161 70 091 0 06	FASCIA Elastica AC Ø 53,2	SEGMENT De Piston	PISTON Ring	2	
	161 70 091 0 07	FASCIA Elastica ROS Ø 53,2	SEGMENT De Piston	PISTON Ring	2	
	161 70 091 0 08	FASCIA Elastica ROF Ø 53,2	SEGMENT De Piston	PISTON Ring	2	
	161 70 091 0 09	FASCIA Elastica AC Ø 53,4	SEGMENT De Piston	PISTON Ring	2	
	161 70 091 0 10	FASCIA Elastica ROS Ø 53,4	SEGMENT De Piston	PISTON Ring	2	
	161 70 091 0 11	FASCIA Elastica ROF Ø 53,4	SEGMENT De Piston	PISTON Ring	2	
	161 70 091 0 12	FASCIA Elastica AC Ø 53,6	SEGMENT De Piston	PISTON Ring	2	
	161 70 091 0 13	FASCIA Elastica ROS Ø 53,6	SEGMENT De Piston	PISTON Ring	2	
	161 70 091 0 14	FASCIA Elastica ROF Ø 53,6	SEGMENT De Piston	PISTON Ring	2	
	2	161 70 457 0 80	PISTONE Con Fig.1-3-4 Ø 53	PISTON	PISTON	2
		161 70 457 1 80	PISTONE Con Fig.1-3-4 Ø 53,2	PISTON	PISTON	2
161 70 457 2 80		PISTONE Con Fig.1-3-4 Ø 53,4	PISTON	PISTON	2	
161 70 457 3 80		PISTONE Con Fig.1-3-4 Ø 53,6	PISTON	PISTON	2	
3	161 70 091 0 04	SPINOTTO Pistone	AXE De Piston	PISTON Pin	2	
4	161 70 091 0 05	ANELLINO	ANNEAU	CLIP	4	
5	000 1011 05 2 3	DADO	ECROU	NUT	3	
6	000 1101 05 4 3	RONDELLA Piana	RONDELLE	WASHER	3	
7	211 03 010 0 00	RONDELLA Conica	RONDELLE Conique	TAPER Washer	3	
8	000 3160 01 1 3	VITE T.S. Ø 5Max10	VIS T.S. Ø 5Max30	SCREW Dia. 5Max30	5	
9	000 3158 01 1 3	VITE T.S. Ø 5Max20	VIS T.S. Ø 5Max20	SCREW Dia. 5Max20	1	
10	211 03 010 0 00	RONDELLA Conica	RONDELLE Conique	TAPER Washer	3	
11	000 1106 05 4 3	RONDELLA Piana	RONDELLE	WASHER	3	
12	000 1011 05 2 3	DADO	ECROU	NUT	3	
13	000 1050 00 2 3	DADO	ECROU	NUT	1	
14	211 03 011 0 00	PIGNONE Frizione	PIGNON Embrayage	CLUTCH Pinion	1	
15	148 47 310 0 00	MOLLA A Tazza	RESSORT A Tasse	CUP Spring	4	
16	211 03 012 0 00	DISTANZIALE	ENTRETOISE	SPACER	1	
17	000 5771 01 1 3	CUSCINETTO 25x62x17	ROULEMENT 25x62x17	BEARING 25x62x17	1	
18	211 03 030 0 80	ALBERO Motore Composto	VILEBREQUIN	ENGINE Shaft Complete	1	
19	000 6398 18 0 0	RULLI	EGUILLES	ROLLERS	15	
20	000 6399 05 1 1	RULLO	EGUILLE	ROLLER	1	
21	000 6120 01 2 2	CUSCINETTO 25x52x18	ROULEMENT 25x52x18	BEARING 25x52x18	1	
22	211 03 020 0 00	PIGNONE Camme	PIGNON De Distribution	CAM Pinion	1	
23	000 1125 34 0 0	RONDELLA Piana	RONDELLE	WASHER	1	
24	000 1049 00 2 3	DADO	ECROU	NUT	1	
25	000 5603 34 0 1	GUARNIZIONE 17x28x6	JOINT 17x28x6	GASKET 17x28x6	1	
26	211 03 033 0 00	ANELLO Elastico	CIRCLIP	CLIP	1	

TAB.N°2

BIELLA-PISTONE

BIELLE-PISTON

CONN. ROD-PISTON

FIG.	ORD. N°	DESCRIZIONE	DESCRIPTION	DESCRIPTION	QT.
27	211 03 032 0 00	ANELLO Centrale	ANNEAU Centrale	RACE	1
28	199 02 014 0 00	BUSSOLA Fermo Anello	BAGUE D'Arrete	BUSHING	1
29	211 03 034 0 80	SOSTEGNO Anello con figura 33-34-35	SOUTIEN de l'Anneau avec fig. 33-34-35	RING SUPPORT With fig. 33-34-35	1
30	000 1362 01 3 3	VITE T.E. $\varnothing$ 6Max35	VIS T.E. $\varnothing$ 6Max35	SCREW Dia. 6Max35	6
31	000 1108 06 6 8	RONDELLA Curvata	RONDELLE Courbe	WASHER	6
32	000 5600 04 1 0	GUARNIZIONE OR	JOINT OR	"O" Ring	1
33	199 10 068 0 00	BUSSOLA Centraggio	DOUILLE de Centrage	BUSHING	1
34	000 1064 08 7 0	DADO Autofrenato	ECROU Autobloquant	SELF Locking nut	2
35	000 2264 01 3 3	VITE E.I. $\varnothing$ 8Max70	VIS E.I. $\varnothing$ 8Max70	SCREW Dia 8Max70	2

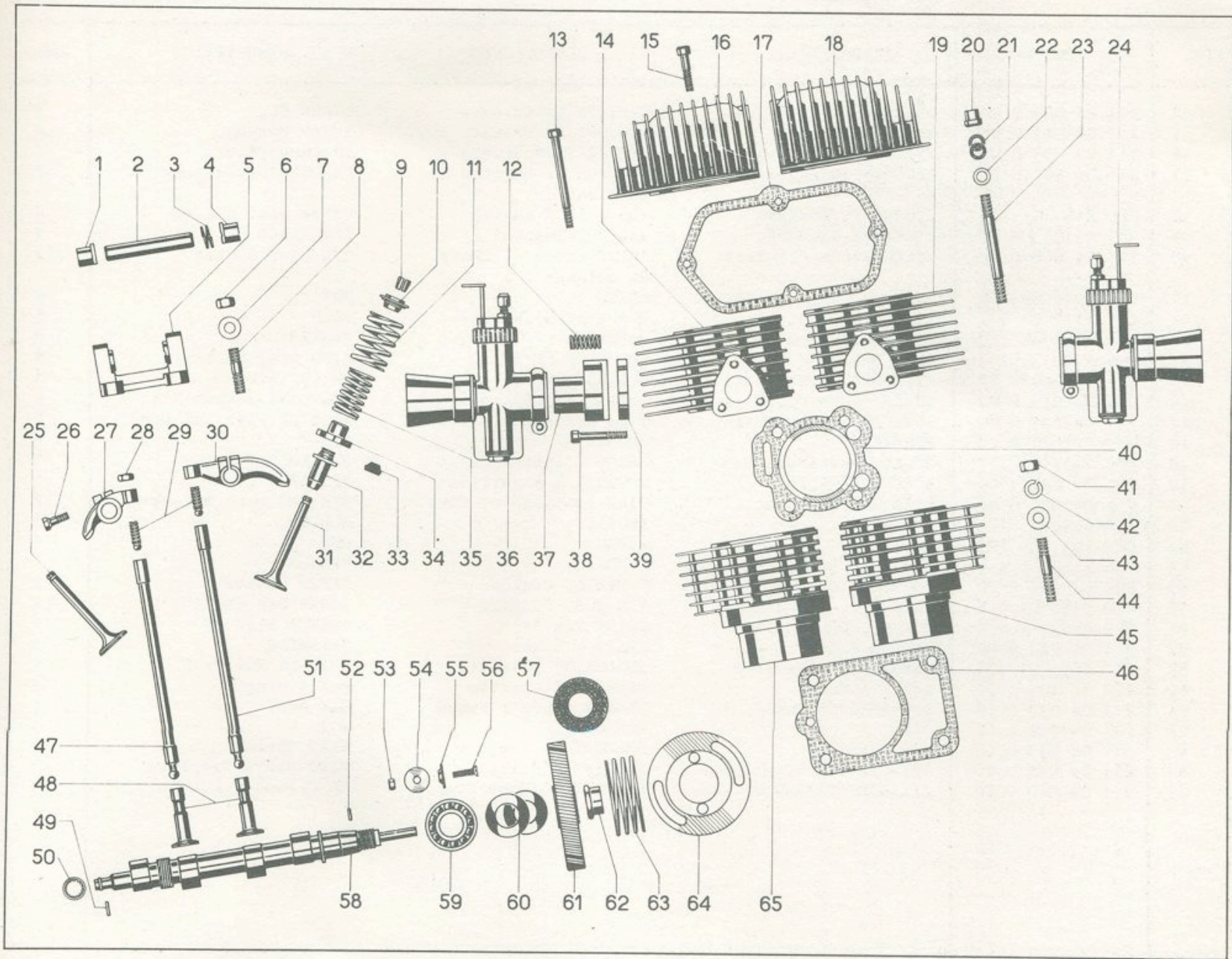

FIG.	ORD. N°	DESCRIZIONE	DESCRIPTION	DESCRIPTION	QT.
1	171 82 188 0 13	BOCCOLA	DOUILLE	BUSHING	4
2	211 04 010 0 00	PERNO Bilancere	AXE du Culbuteur	ROCKER Hinge	4
3	148 47 017 0 00	MOLLA Assiale	RESSORT Axial	AXIAL Spring	4
4	171 82 188 0 09	BOCCOLA Lato Asta	DOUILLE Coté Tige	BUSHING	4
5	211 04 011 0 80	SUPPORTO Bilancere con fig. 1-4	SUPPORT du Culbuteur avec fig. 1-4	ROCKER Support With fig. 1-4	2
6	000 1012 08 2 3	DADO	ECROU	NUT	8
7	000 1101 08 4 3	RONDELLA Piana	RONDELLE	WASHER	8
8	000 4100 42 3 3	PRIGIONIERO Ø8Max37	GOUJON Ø8Max37	STUD Dia. 8Max37	8
9	199 03 028 0 00	SEMICONO	BAGUE Conique En2.Pieces	HALF-CONE	4
10	211 04 007 0 00	PIATTELLO Superiore	CUVETTE Superieure	UPPER Cap	4
11	211 04 013 0 00	MOLLA Esterna	RESSORT Estèrieure	EXT Spring	4
12	122 05 035 0 00	MOLLA	RESSORT	SPRING	6
13	000 2168 01 3 3	VITE E.I. Ø 6Max75	VIS E.I.Ø 6Max75	SCREW Dia.6Max75	4
14	211 04 002 0 80	TESTA Sinistra con fig. 32	CULASSE Gauche avec fig. 32	LH-HEAD With fig. 32	1
15	000 2159 01 3 3	VITE E.I. Ø6Max30	VIS E.I. Ø6Max30	SCREW Dia 6Max30	4
16	211 04 015 0 00	CAPPELLO Sinistro	COUVERCLE Gauche	LH Cap	1
17	211 04 017 0 00	GUARNIZIONE Cappello	JOINT du Couvercle	GASKET	2
18	211 04 016 0 00	CAPPELLO Destro	COUVERCLE Droite	RH Cap	1
19	211 04 003 0 80	TESTA Destra con fig. 32	CULASSE Droite avec fig. 32	RH Head With fig. 32	1
20	211 04 047 0 00	DADO	ECROU	NUT	8
21	000 1121 08 2 1	RONDELLA Di Sicurezza	RONDELLE de Sécurité	SAFETY Washer	16
22	000 1125 01 0 0	RONDELLA Piana	RONDELLE	WASHER	8
23	000 4100 37 3 3	PRIGIONIERO Ø 8Max90	GOUJON Ø 8Max90	STUD Dia 8Max90	8
24	211 05 002 0 00	CARBURATORE Destro	CARBURATEUR Droit	RH Carburator	1
25	211 04 004 0 00	VALVOLA Aspirazione	SOUPAPE Admission	SUCTION Valve	2
26	000 5513 00 3 3	VITE Fissaggio	VIS De Fissage	SCREW	4
27	211 04 008 0 00	BILANCERE Aspirazione	CULBUTEUR Admission	SUCTION Rocker	2
28	000 1013 07 2 3	DADO	ECROU	NUT	4
29	211 04 020 0 00	VITE Registro Gioco	VIS Pour Reglage du jeu	ADJUSTING Screw	4
30	211 04 009 0 00	BILANCERE Scarico	CULBUTEUR Echappement	EXHAUST Rocker	2
31	211 04 005 0 00	VALVOLA Scarico	SOUPAPE d'échappement	EXHAUST Valve	2
	161 70 015 2 00	GUIDA Valvola	GUIDE Soupape	VALVE Guide	4
32	161 70 015 2 01	GUIDA Valvola + 0,1	GUIDE Soupape + 0,1	VALVE Guide + 0,1	4
	161 70 015 2 02	GUIDA Valvola + 0,2	GUIDE Soupape + 0,2	VALVE Guide + 0,2	4
33	161 70 016 0 00	GUARNIZIONE su Stelo	JOINT sur la Tige de Soupape	STEM Gasket	4

FIG.	ORD. N°	DESCRIZIONE	DESCRIPTION	DESCRIPTION	QT.
34	211 04 006 0 00	PIATTELLO Inferiore	CUVETTE Inférieure	LOWER Cap	4
35	211 04 012 0 00	MOLLA Interna	RESSORT Intérieur	INNER Spring	4
36	211 05 003 0 00	CARBURATORE Sinistro	CARBURATEUR Gauche	LH Carburator	1
37	211 05 001 0 00	RACCORDO Carburatore	MANCHON de Raccord du Carburateur	CARBURATOR Fitting	2
38	000 2161 01 3 3	VITE E.I. Ø6Max40	VIS E.I. Ø 6Max40	SCREW Dia. 6Max40	6
39	199 04 033 0 00	ISOLANTE Raccordo	RACCORD Isolant	INSULATOR	2
40	211 04 046 0 00	GUARNIZIONE Cil-Testa	JOINT entre cylindre et culasse	CYL-HEAD Gasket	2
41	000 1012 08 2 3	DADO	ECROU	NUT	8
42	000 1111 08 6 3	RONDELLA Elastica	RONDELLE Elastique	CLIP	8
43	000 1101 08 4 3	RONDELLA Piana	RONDELLE	WASHER	8
44	000 4100 36 3 3	PRIGIONIERO Ø 8Max52	GOUJON Ø 8Max52	STUD Dia. 8Max52	8
45	211 04 042 0 80	CILINDRO Destro Comp.	CYLINDRE Droit Complet	RH Cylinder	1
46	211 04 045 0 00	GUARNIZIONE Cilindro-	JOINT entr Cylindre	CYL-Case Gasket	2
47	211 04 021 0 80	ASTA Aspirazione comp.	Tige Admission Comp.	SUCTION Push Rod Comp.	2
48	211 04 026 0 00	PUNTALINO	POUSSOIR	CAF	4
49	000 6399 04 1 1	RULLO Trascinamento	ERGOT d'Entrainement	ROLLER	1
50	161 70 146 1 00	BOCCOLA Rullini	DOUILLE à Aiguilles	BUSHING	1
51	211 04 025 0 80	ASTA Scarico Comp.	TIGE Echappement Comp.	EXHAUST Push Rod-Comp.	2
52	000 6399 05 1 1	RULLO	EGUILLE	ROLLER	1
53	000 1011 05 2 3	DADO	ECROU	NUT	2
54	000 1106 05 4 3	RONDELLA Piana	RONDELLE	WASHER	1
55	211 03 010 0 00	RONDELLA Conica	RONDELLE Conique	TAPER Washer	2
56	000 3158 01 1 3	VITE T.S. Ø 5Max20	VIS T.S. Ø5Max20	SCREW Dia 5Max20	2
57	000 5603 11 0 1	GUARNIZIONE 22x45x7	JOINT 22x45x7	GASKET 22x45x7	1
58	211 04 027 0 00	ALBERO Camme	ARBRE à cames	CAMSHAFT	1
59	000 5693 01 1 2	CUSCINETTO 20x42x12	RDULEMENT 20x42x12	BEARING 20x42x12	1
60	172 84 103 0 00	MOLLA A Tazza	RESSORT à Cuvette	CUP Spring	2
61	211 04 030 0 00	INGRANAGGIO Camme	PIGNON Arbre à cames	CAM Gear	1
62	211 04 032 0 00	DADO	ECROU	NUT	1
63	211 04 033 0 00	MOLLA Sfiato	RESSORT de l'évant	VENT Spring	1
64	211 04 034 0 80	VALVOLA Sfiato comp.	SOUPAPE d'évant comp.	VENT Valve-Complete	1
65	211 04 040 0 80	CILINDRO Sinistro Comp.	CYLINDRE Gauche Comp.	LH Cylinder complete	1

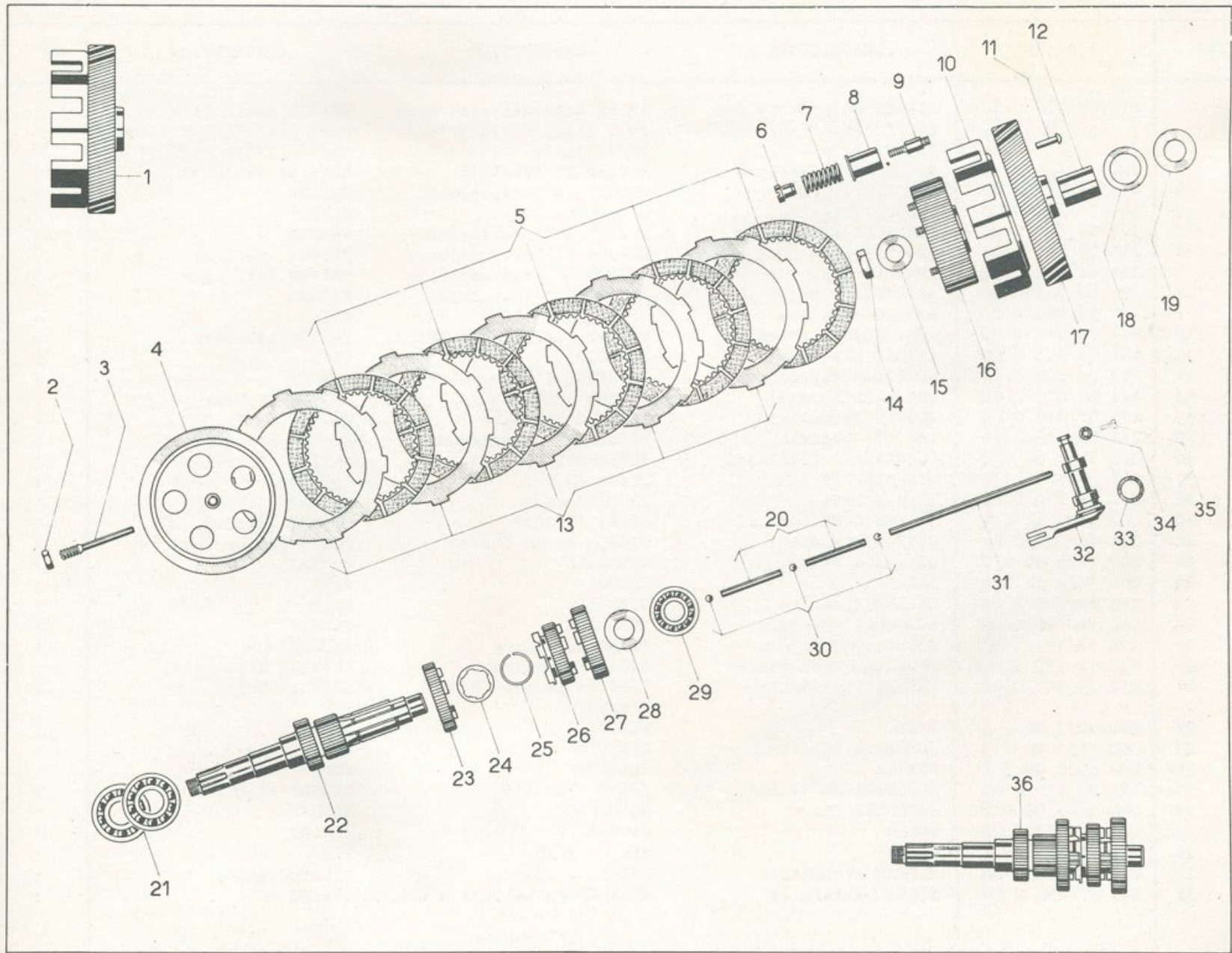

FIG.	ORD. N°	DESCRIZIONE	DESCRIPTION	DESCRIPTION	QT.
1	211 07 001 0 80	INGRANAGGIO Frizione con figura 10	PIGNON Embrayage avec fig. 10	CLUTCH Gear with fig. 10	1
2	000 1015 08 2 3	DADO	ECROU	NUT	1
3	169 81 102 1 00	VITE Regolaggio	VIS de Reglage	ADJUSTING Screw	1
4	169 81 097 1 00	DISCO Premifrizione	DISQUE de la Butée de débrayage	CLUTCH Disc	1
5	169 81 099 1 00	DISCO CONDOTTO	Disque Conduit	DRIVEN Disc	5
6	169 81 094 1 00	DADO	ECROU	NUT	5
7	199 05 013 0 00	MOLLA	RESSORT	SPRING	5
8	211 07 005 0 00	FONDELLO	CORVERCLE	BOTTOM	5
9	211 07 004 0 00	COLONNINA	AXE	COLUMN	5
10	171 82 453 0 00	CUSTODIA Frizione	BOITE Embrayage	CLUTCH Housing	1
11	000 1133 08 1 8	RIBATTINO	RIVET	RIVET	8
12	211 07 002 0 00	BOCCOLA Distanziale	BAGUE Entretoise	SPACER	1
13	171 82 458 0 00	DISCO Conduttore	DISQUE Conducteur	DRIVEN Disc	5
14	000 1035 00 2 3	DADO	ECROU	NUT	1
15	000 1125 60 0 0	RONDELLA Piana	RONDELLE	WASHER	1
16	211 07 003 0 80	ROCCHETTO Friz.con fig.9	PIGNON Embrayage avec fig. 9	CLUTCH SPROCKET with fig. 9	1
17	211 07 001 0 00	INGRANAGGIO Frizione	PIGNON Embrayage	CLUTCH Gear	1
18	000 1125 67 0 0	RONDELLA Rasamento	RONDELLE de Réglage	WASHER	1
19	000 1125 66 0 0	RONDELLA fra Cusc. e Boccola	RONDELLE entre Roulement et Douille	WASHER Between bearing and Bushing	1
20	171 82 456 0 00	ASTA Centrale	TIGE Centrale	ROD	2
21	000 5735 01 1 3	CUSCINETTO 20x47x14	ROULEMENT 20x47x14	BEARING 20x47x14	2
22	211 08 001 0 00	ALBERO Primario	ARBRE Primaire	DRIVE Shaft	1
23	211 08 002 0 00	INGRANAGGIO IV Prim.	PIGNON IV Primaire	4th. DRIVE Gear	1
24	199 06 005 0 00	RONDELLA Ritegno	ARRETOIR	WASHER	1
25	151 51 063 0 00	ANELLO Elastico	CIRCLIP	CLIP	1
26	211 08 003 0 00	INGRANAGGIO SCORR.III°p.	PIGNON Coulissant III°p.	Ed. DRIVE Gear	1
27	211 08 004 0 00	INGRANAGGIO V° Prim.	PIGNON V° Prim.	5th. DRIVE Gear	1
28	171 82 186 0 04	RONDELLA	RONDELLE	WASHER	1
29	000 5734 01 1 2	CUSCINETTO 17x40x12	ROULEMENT 17x40x12	BEARING 17x40x12	1
30	000 6397 05 1 0	SFERA 3/16	DOUILLE 3/16	BALL 3/16	3
31	211 07 010 0 00	ASTA Esterna	TIGE Exterieur	EXT. Rod	1
32	211 07 011 0 00	LEVA Frizione	LEVIER Embrayage	CLUTCH Lever	1
33	000 5600 20 1 0	GUARNIZIONE OR	JOINT OR	"O" Ring	1
34	000 1126 11 0 0	RONDELLA	RONDELLE	WASHER	1
35	000 5517 00 0 0	VITE Fermo leva	VIS D'Arrêt du levier	SCREW	1
36	211 08 001 0 80	ALBERO Primario con fig. 23-24-25-26-27-28	ARBRE Primaire avec fig. 23-24-25-26-27-28	DRIVE Shaft with fig. 23-24-25-26-27-28	1

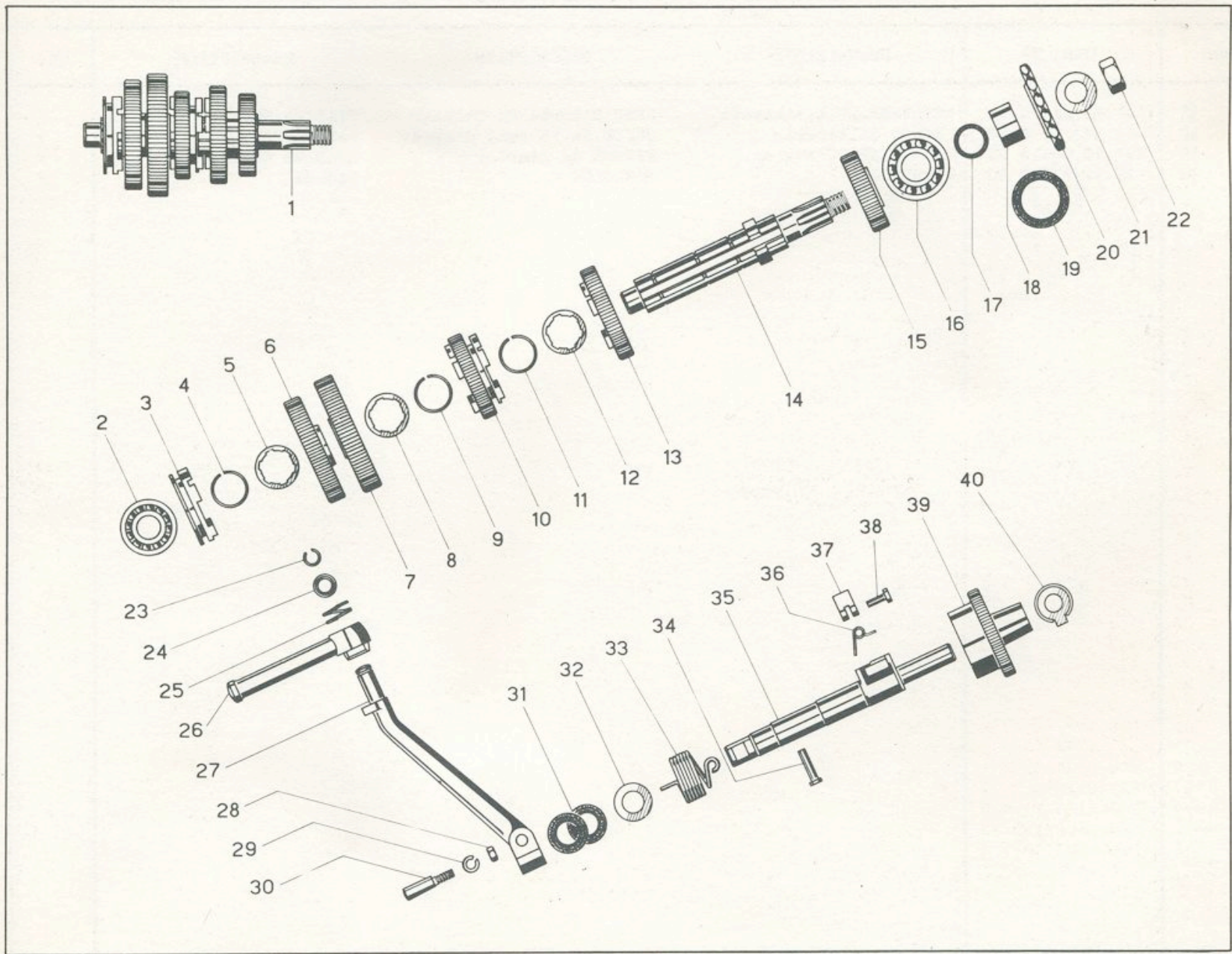



FIG.	ORD. N°	DESCRIZIONE	DESCRIPTION	DESCRIPTION	QT.
1	211 08 010 0 80	ALBERO Secondario con fig.3/4/5/6/7/8/9/10/11/12/13/14	ARBRE Intermédiaire avec fig. 3/4/5/6/7/8/9/10/11/12/13/14	DRIVEN SHAFT With fig. 3/4/5/6/7/8/9/10/11/12/13/14	1
2	000 5734 01 1 2	CUSCINETTO 17x40x18	ROULEMENT 17x40x18	BEARING 17x40x18	1
3	211 08 011 0 00	INNESTO II°Sec.	EMBAYAGE II°Intermed.	SLIDER	1
4	151 51 063 0 00	ANELLO Elastico	CIRCLIP	CLIP	1
5	199 06 005 0 00	RONDELLA Ritegno	RONDELLE D'Etancheité	WASHER	1
6	211 08 012 0 00	ING.II° Sec.	PIGNON II°Intermédiaire	DRIVEN 2nd.Gear	1
7	211 08 013 0 00	ING. I° Sec.	PIGNON I° Intermédiaire	DRIVEN 1st. Gear	1
8	199 06 005 0 00	RONDELLA Ritegno	RONDELLE d'Etancheité	WASHER	1
9	151 51 063 0 00	ANELLO Elastico	CIRCLIP	CLIP	1
10	211 08 014 0 00	ING. SCORR.IV° SEC.	PIGNON Coulissant IV°int.	DRIVEN 4th.Gear	1
11	151 51 063 0 00	ANELLO Elastico	CIRCLIP	CLIP	1
12	199 06 005 0 00	RONDELLA Ritegno	RONDELLE d'Etancheité	WASHER	1
13	211 08 015 0 00	ING. III°Second.	PIGNON III°Intermédiaire	DRIVEN 3d.Gear	1
14	211 08 010 0 00	ALBERO Secondario	ARBRE Secondaire	DRIVEN Shaft	1
15	211 08 016 0 00	ING. V° Second.	PIGNON V° Intermédiaire	DRIVEN 5th.Gear	1
16	000 5735 01 1 3	CUSCINETTO 20x47x14	ROULEMENT 20x47x14	BEARING 20x47x14	1
17	000 5607 08 1 0	GUARNIZIONE OR	JOINT OR	"O" Ring	1
18	211 08 020 0 00	DISTANZIALE	ENTRETOISE	SPACER	1
19	000 5603 36 0 1	GUARNIZIONE 28x40x7	JOINT 28x40x7	GASKET 28x40x7	1
20	211 08 021 0 00	PIGNONE Catena	PIGNON de la Chaîne	CHAIN Pinion Gear	1
21	000 1125 60 0 0	RONDELLA Piana	RONDELLE	WASHER	1
22	000 1014 14 2 3	DADO	ECROU	NUT	1
23	132 14 180 1 02	ANELLO Elastico	CIRCLIP	CLIP	1
24	132 14 180 1 01	RONDELLA Appoggio	RONDELLE	WASHER	1
25	132 14 181 1 00	DOPPIA Rondella	RONDELLE Double	WASHER	1
26	132 14 170 0 00	PEDALINO Ribaltabile	PEDALE du starter	MOVABLE Kick Pedal	1
27	211 10 005 0 00	PEDALE Avviamento	TIGE de la pèdale du starter	STARTER Pedal	1
28	000 1013 06 2 3	DADO	ECROU	NUT	1
29	000 1111 06 6 3	RONDELLA Elastica	CIRCLIP	CLIP	1
30	000 5531 00 3 7	BIETTA	CLAVETTE	KEY	1
31	125 08 090 1 01	GUARNIZIONE 17x28x45	JOINT 17x28x45	GASKET 17x28x45	2
32	000 1125 39 0 0	RONDELLA Piana	RONDELLE	WASHER	1
33	125 08 074 0 00	MOLLA	RESSORT	SPRING	1
34	000 5107 00 1 3	SPINA	AXE	PIN	1
35	211 10 002 0 00	ALBERO Avviamento	ARBRE du Starter	STARTER Shaft	1
36	148 47 158 0 00	MOLLA Saltarello	RESSORT de La Dent d'arr.	SPRING	1

TAB.N°5

ALBERO SEC.-AVVIAMENTO

ARBRE SEC.-DEMARRAGE

DRIVEN SHAFT-STARTER

FIG.	ORD. N°	DESCRIZIONE	DESCRIPTION	DESCRIPTION	QT.
37	148 47 157 0 00	SALTARELLO Avviamento	DENT D'Arrêt du Starter	STARTER Pawl	1
38	143 31 116 0 00	PERNO Saltarello	GUJON de la Dent d'arrêt	PAWL Hinse	1
39	211 10 001 0 00	INGRANAGGIO Avviam.	PIGNON du Starter	STARTER Gear	1
40	129 11 028 0 00	RONDELLA	RONDELLE	WASHER	1

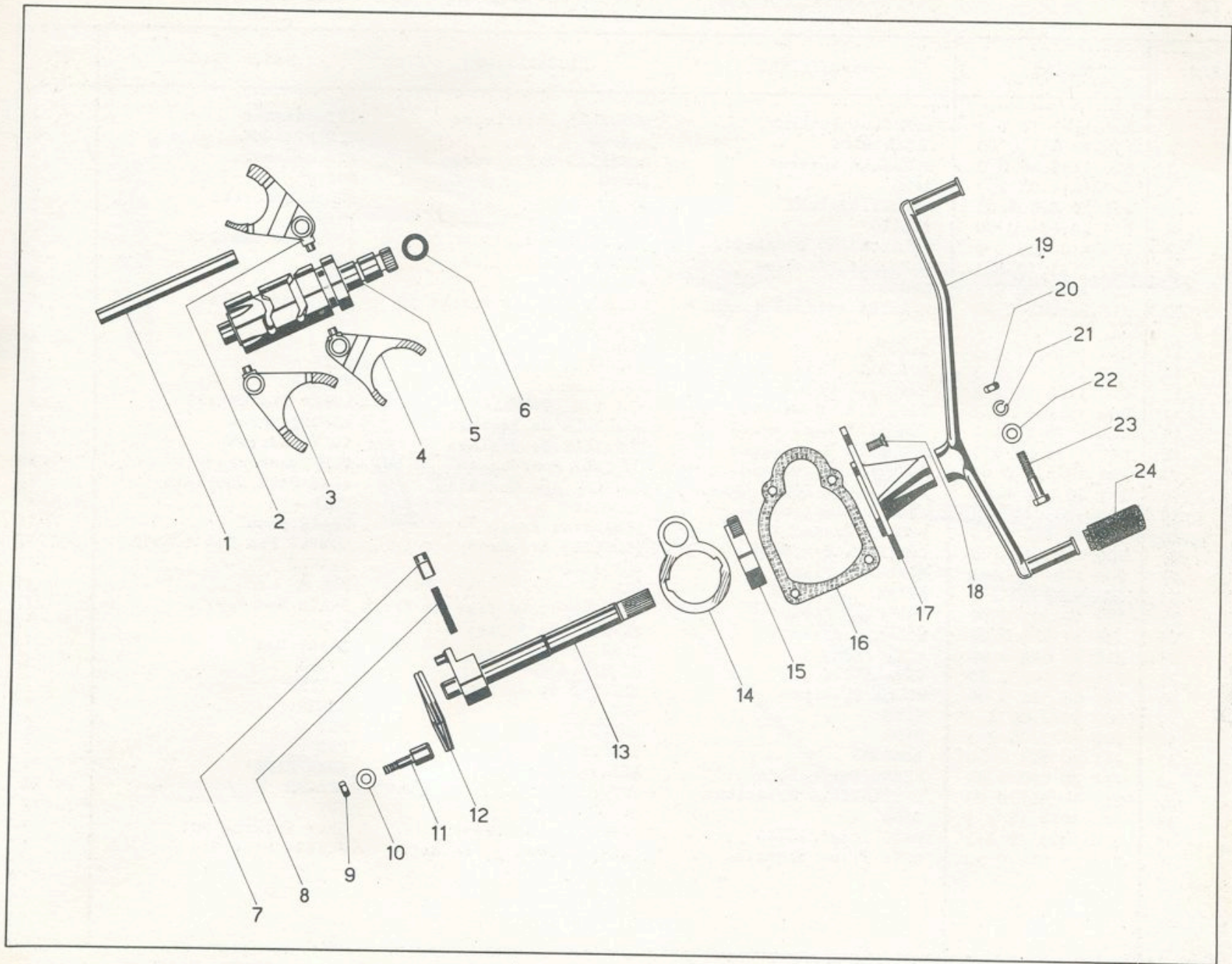
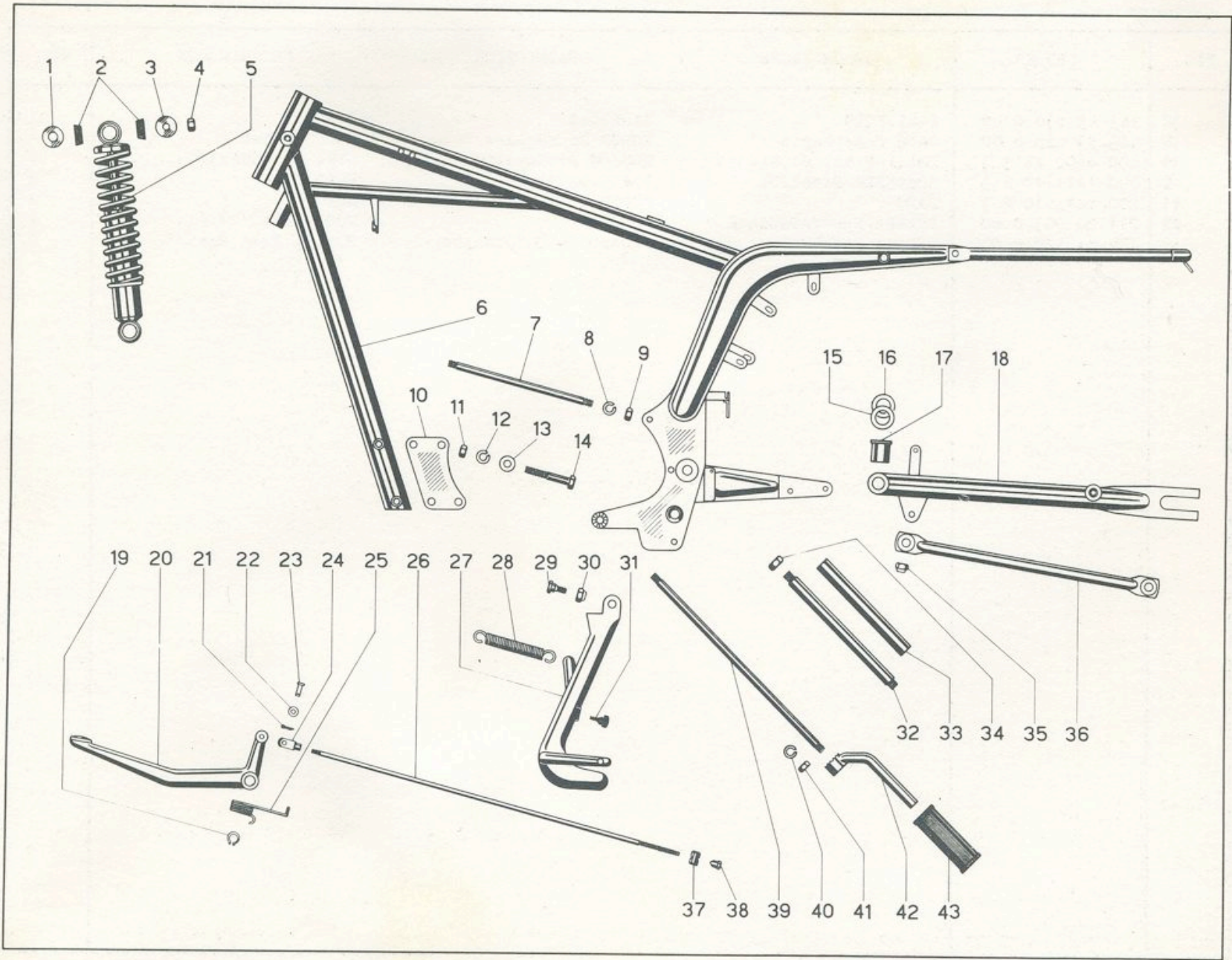

FIG.	ORD. N°	DESCRIZIONE	DESCRIPTION	DESCRIPTION	QT.
1	211 09 004 0 00	PERNO Forcellino	AXE de la Fourchette	FORK Hinge	2
2	211 09 003 0 00	FORCELLINO IV -V Vel.	FOURCHETTE IV-V Vitesse	FORK 4th-5th Gear	1
3	211 09 001 0 00	FORCELLINO II Vel.	FOURCHETTE II Vitesse	FORK 2nd Gear	1
4	211 09 002 0 00	FORCELLINO I-III Vel.	FOURCHETTE I-III Vitesse	FORK 1st.3d.Gear	1
5	211 09 005 0 00	CAMMA Cambio	CAME du Changement de Vitesse	CAM	1
6	000 5600 16 1 0	GUARNIZIONE OR	JOINT	"O" Ring	1
7	125 08 069 0 00	SALTARELLO Selettore	DENTE du Sélecteur	SELECTOR	2
8	125 08 065 0 01	MOLLA Saltarello	RESSORT de la Dente	SPRING	1
9	000 1013 06 2 3	DADO	ECROU	NUT	1
10	000 1101 06 4 3	RONDELLA Piana	RONDELLE	WASHER	1
11	211 09 013 0 00	PIOLO Fermo Molla	CHEVILLE d'arrêt du ressort	SPRING Holder	1
12	125 08 071 0 00	MOLLA Albero	RESSORT de l'Arbre	SPRING	1
13	211 09 010 0 80	ALBERO Selettore	ARBRE Selecteur	SELECTOR SHaft	1
14	211 09 010 0 00	PIASTRINA	PLAQUETTE	PLATE	1
15	211 09 006 0 00	SETTORE Camma	SECTEUR Came	CAM Sector	1
16	211 02 022 0 00	GUARNIZIONE	JOINT	GASKET	1
17	211 02 021 0 00	COPERCHIO Selettore	COUVERCLE du Sélecteur	COVER	1
18	000 3202 01 3 3	VITE T.S. Ø 6Max14	VIS T.S. Ø 6Max14	SCREW Dia. 6Max14	4
19	211 09 012 0 00	PEDALE Cambio	PEDALE du Changement de v.	GEAR Change Pedal	1
20	000 1013 06 2 3	DADO	ECROU	NUT	1
21	000 1111 06 6 3	RONDELLA Elastica	RONDELLE Elastique	CLIP	1
22	000 1101 06 4 3	RONDELLA Piana	RONDELLE	WASHER	1
23	000 1362 01 3 3	VITE T.E. Ø6Max35	VIS T.E. Ø 6Max35	SCREW Dia.6Max35	1
24	129 11 312 0 00	PEDALINO Gomma	PEDALE en Caoutchouc	RUBBER Footrest	2



TAB. N°7

TELAIO-FORCELLONE-AMM.

CADRE-FOURCHE-AMORTISSEUR

FRAME-REAR FORKS-

FIG.	ORD.N°	DESCRIZIONE	DESCRIPTION	DESCRIPTION	QT.
1	000 1101 12 4 3	RONDELLA Interna	RONDELLE Interieure	INT. Washer	3
2	136 19 631 0 00	SILENTBLOC	TAMPON	SILENTBLOCK	8
3	000 1105 08 0 0	RONDELLA Esterna	RONDELLE Exterieure	EXT. Washer	4
4	000 1011 08 2 3	DADO	ECROU	NUT	4
5	211 20 008 0 00	AMMORTIZZATORE	AMORTISSEUR	SHOCK Absorber	2
6	211 20 001 0 80	TELAIO	CADRE	FRAME	1
7	000 4100 39 3 3	PRIGIONIERO Ø10Max212	GOUJON Ø10Max212	STUD DIA10Max212	1
8	000 1111 10 6 3	RONDELLA Elastica	RONDELLE Elastique	CLIP	2
9	000 1013 10 2 3	DADO	ECROU	NUT	2
10	211 20 002 0 00	PIASTRA Attacco Motore	PLAQUE Pour le Fixage du Moteur	ENG.Attach Plate	2
11	000 1013 10 2 3	DADO	ECROU	NUT	4
12	000 1111 10 6 3	RONDELLA Elastica	RONDELLE Elastique	CLIP	4
13	000 1101 10 4 3	RONDELLA Piana	RONDELLE	WASHER	4
14	000 1563 01 3 3	VITE T.E. Ø10Max65	VIS T.E. Ø10Max65	SCREW DIA10Max65	4
15	000 1125 61 0 0	RONDELLA Regolaggio	RONDELLE De Réglage	ADJUST.Screw	
16	000 1125 62 0 0	RONDELLA Regolaggio	RONDELLE De Réglage	ADJUST.Screw	
17	136 19 848 0 01	BOCCOLA Forcellone	DOUILLE Fourche AR	FORK Bushing	2
18	211 20 005 0 80	FORCELLONE Post. Comp.	FOURCHE AR. Complete	REAR Fork Complete	1
19	000 5064 13 0 0	ANELLO Elastico	CIRCLIP	CLIP	1
20	211 20 010 0 80	PEDALE Freno	PEDALE du Frein	BRAKE Pedal	1
21	000 1131 18 1 8	COPIGLIA Ø 1,8x18	GOUPIILLE Ø 1,8x18	COTTER Pin Dia 1,8x18	1
22	000 1101 06 4 3	RONDELLA Piana	RONDELLE	WASHER	1
23	000 5103 00 3 3	SPINA	AXE	PIN	1
24	199 10 101 0 00	FORCELLA Freno	FOURCHE de La Tige du Frein	BRAKE Rod Fork	1
25	136 19 629 0 00	MOLLA Richiamo	RESSORT de Rappel	SPRING	1
26	211 20 014 0 00	ASTA Freno	TIGE du Frein	BRAKE Rod	1
27	211 20 009 0 80	CAVALLETTO	BEQUILLE	STAND	1
28	127 08 526 0 00	MOLLA Richiamo	RESSORT du Rappel	SPRING	2
29	000 5542 00 3 3	VITE	VIS	SCREW	2
30	000 1023 08 2 3	DADO	ECROU	NUT	1
31	211 20 013 0 00	TAMPONE	TAMPON	PAD	1
32	211 20 006 0 00	PERNO Forcellone	AXE Fourche AR.	FORK Hinge	1
33	211 20 007 0 00	DISTANZIALE Rotazione	ENTRETOISE	SPACER	1
34	000 1014 12 2 3	DADO	ECROU	NUT	2
35	000 1023 18 2 3	DADO Autofrenato	ECROU Autobloquat	SELF Locking Nut	1
36	211 25 015 0 80	ASTA Fermo Flangia	TIGE d'Arret de la Bride	FLANGE Stop Rod	1

TAB. N°7

TELAIO-FORCELLONE-AMM.

CADRE-FOURCHE-AMORTISSEUR

FRAME-REAR PROKS-

FIG.	ORD.N°	DESCRIZIONE	DESCRIPTION	DESCRIPTION	QT.
37	163 53 030 0 00	BARILETTO	BARILLET	BARREL	1
38	163 53 025 0 00	DADO Regolaggio	ECROU de Réglage	ADJUST. Nut	1
39	000 4100 44 3 3	FRIGIONIERO Ø10Max345	GOUJON Ø10Max345	STUD Dia10Max345	2
40	000 1111 10 6 3	RONDELLA Elastica	RONDELLE Elastique	CLIP	2
41	000 1013 10 2 3	DADO	ECROU	NUT	2
42	211 20 003 0 00	PEDANA Appoggiapiedi	PEDALE	FOOT Rest	2
43	172 84 528 0 00	PEDANA Gomma	PEDALE en Caoutchouc	RUBBER Foot Rest	2

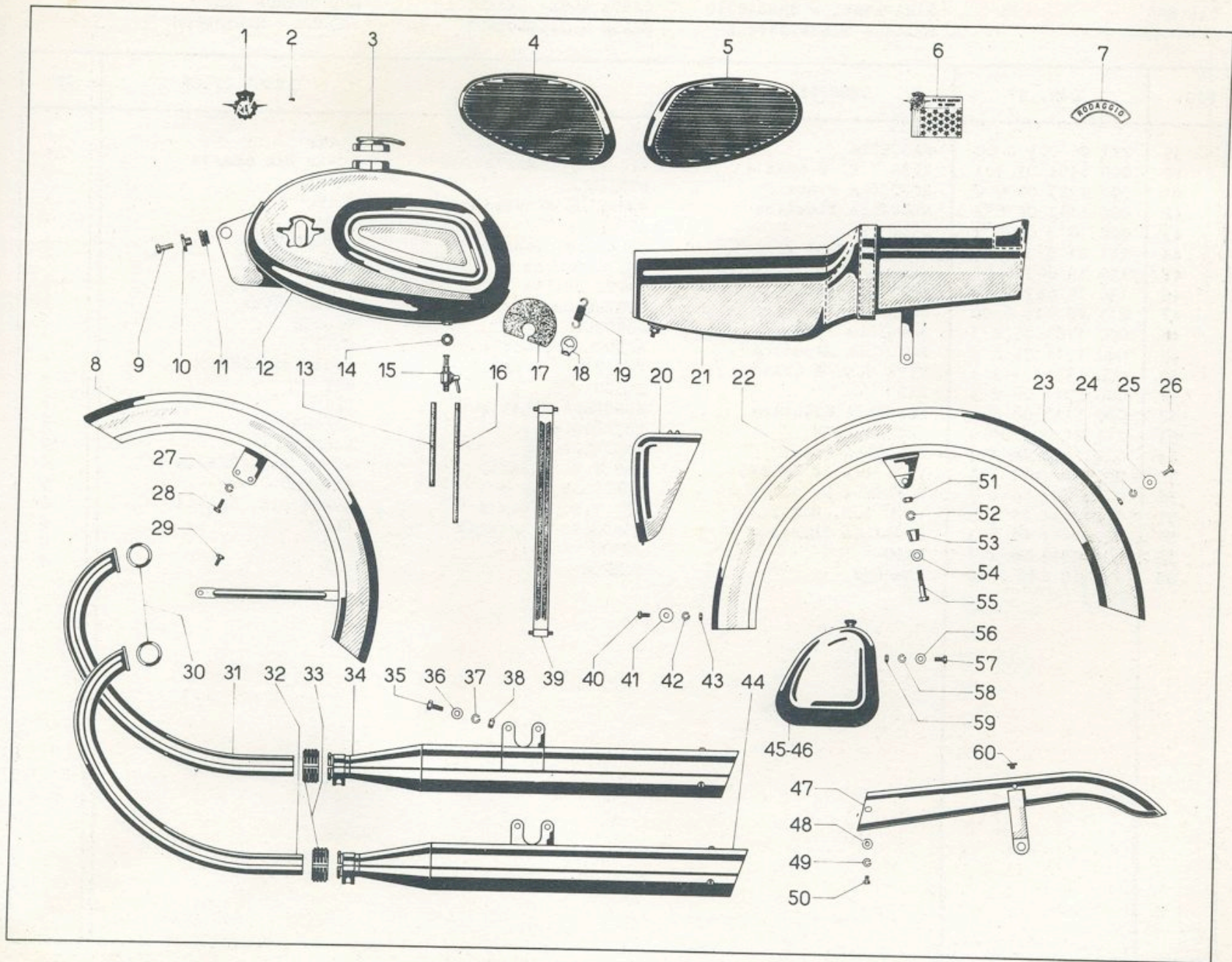



TAB.N°8

PARAFANGHI- SERBATOIO  
SELLA SILENZIATOREGARDE BOUE- RESERVOIR  
SELLE- SILENCIEUXMUD GUARD - TANK  
SADDLE - SILENCERS

FIG.	ORD.N°	DESCRIZIONE	DESCRIPTION	DESCRIPTION	QT.
1	199 11 026 0 00	DISTINTIVO	ENSIGNE	BADGE	2
2	000 4C02 02 1 8	VITE	VIS	SCREW	4
3	211 21 004 0 00	TAPPO Serbatoio	BOUCHON du Réservoir	FUEL Filler Cap	1
4	199 11 028 0 00	GINOCCHIERA Sinistra	GRIPPE Genoux Gauche	LH KNEE Protection	1
5	199 11 027 0 00	GINOCCHIERA Destra	GRIPPE Genoux Droite	RH KNEE Protection	1
6	172 84 564 0 00	CALCOMANIA "Trofei"	DECALCOMANIE "Trophées"	"TROPHIES" Decal	1
7	136 19 619 0 00	CALCOMANIA "Rodaggio"	DECALCOMANIE "Rodage"	"BREAK-IN" Decal	1
8	211 21 001 0 00	PARAFANGC Anteriore	GARDE-BOUE Av.	FRONT Mud Guard	1
9	000 1455 01 3 3	VITE T. E. Ø8Max22	VIS T.E. Ø8Max22	SCREW Dia.8Max22	2
10	172 84 572 0 00	DISTANZIALE	ENTRETOISE	SPACER	2
11	172 84 574 0 00	SILENTBLOC	TAMPON	SILENTBLOCK	2
12	211 21 005 0 00	SERBATOIO	RESERVOIR	TANK	1
13	000 5539 01 4 0	TUBO Benzina L=140	TUYAU Essence L=140	FUEL LINE L=140	2
14	000 1126 03 0 0	ROSELLA Fibra	RONDELLE n Fibre	FIBRE Washer	2
15	000 5306 00 0 0	ROBINETTO Benzina	ROBINET à essence	FUEL Tap	2
16	000 55 9 02 0 0	TUBO Benzina L=200	TUYAU Essence L=200	FUEL Line L=200	1
17	211 21 007 0 00	SILENTBLOC	TAMPON	SILENTBLOCK	1
18	211 21 008 0 00	GANCIO	VERROU	HOOK	2
19	136 19 862 0 00	MOLLA	RESSORT	SPRING	2
20	211 26 020 0 00	COPRIBATTERIA	COUVERCLE Batterie	BATTERY Cover	1
21	211 21 006 0 00	SELLA	SELLE	SADDLE	1
22	211 21 002 0 00	PARAFANGO Posteriore	GARDE-BOUE Ar.	REAR Mudguard	1
23	000 1013 06 2 3	DADO	ECROU	NUT	1
24	000 1111 06 6 3	RONDELLA Elastica	RONDELLE Elastique	CLIP	1
25	000 1125 09 0 0	RONDELLA Piana	RONDELLE	WASHER	1
26	000 1354 01 3 3	VITE T.E. Ø6Max14	VIS T.E.Ø6Max14	SCREW Dia 6Max14	1
27	000 1111 06 6 3	RONDELLA Elastica	RONDELLE Elastique	CLIP	6
28	000 1356 01 3 3	VITE T.E.Ø6Max18	VIS. T.E.Ø6Max18	SCREW Dia 6Max18	2
29	000 1354 01 3 3	VITE T.E. Ø6Max14	VIS T.E.Ø6Max14	SCREW Dia 6Max18	4
30	125 08 091 0 05	GUARNIZIONE	JOINT	GASKET	2
31	211 21 010 0 80	TUBO Scarico Destro	TUYAU d'échappement droit	RH Exhaust Tube	1
32	211 21 011 0 80	TUBO Scarico Sinistro	TUYAU d'échappement gauche	LH Exhaust Tube	1
33	125 08 009 3 00	GHIERA	ANEAU Fileté	SLEEVE	2
34	211 21 012 0 01	SILENZIATORE Destro	SILENCIEU Droit	RH Silencer	1
35	000 1454 01 3 3	VITE T.E. Ø8Max20	VIS T.E. Ø8Max20	SCREW Dia 8Max20	4
36	000 1101 08 4 3	RONDELLA Piana	RONDELLE	WASHER	4
37	000 1111 08 6 3	RONDELLA Elastica	RONDELLE Elastique	CLIP	4
38	000 1011 08 2 3	DADO	ECROU	NUT	4

TAB. N°8

PARAFANGHI - SERBATOIO  
SELLA - SILENZIATOREGARDE BOUE- RESERVOIR  
SELLE - SILENCIEUXMUD GUARD- TANK  
SADDLE - SILENCERS

FIG.	ORD. N°	DESCRIZIONE	DESCRIPTION	DESCRIPTION	QT.
39	211 26 003 0 00	FASCETTA	COLLIER	CLAMP	1
40	000 1354 01 3 3	VITE T.E. Ø 6Max14	VIS T.E. Ø6Max14	SCREW Dia 6Max14	1
41	000 1125 09 0 0	RONDELLA Piana	RONDELLE	WASHER	1
42	000 1111 06 6 3	RONDELLA Elastica	RONDELLE Elastique	CLIP	1
43	000 1013 06 2 3	DADO	ECROU	NUT	1
44	211 21 013 0 01	SILENZIATORE Sinistro	SILENCIEU Gauche	LH SILENCER	1
45	136 19 663 0 80	SCATOLA Sinistra	BOITE Gauche	LH BOX	1
46	136 19 663 2 80	SCATOLA Destra	BOITE Droite	RH BOX	1
47	211 20 015 0 00	COPRICATENA	COUVRE-CHAINE	CHAIN Cover	1
48	000 1101 06 4 3	RONDELLA Piana	RONDELLE	WASHER	1
49	000 1111 06 6 3	RONDELLA Elastica	RONDELLE Elastique	CLIP	1
50	000 1351 01 3 3	VITE T.E. Ø 6Max8	VIS T.E. Ø 6Max8	SCREW Dia 6Max8	1
51	000 1011 08 2 3	DADO	ECROU	NUT	2
52	000 1111 08 6 3	RONDELLA Elastica	RONDELLE Elastique	CLIP	2
53	211 21 003 0 00	DISTANZIALE	ENTRETOISE	SPACER	2
54	000 1101 08 4 3	RONDELLA Piana	RONDELLE	WASHER	2
55	000 1461 01 3 3	VITE T.E. Ø 8Max45	VIS T.E. Ø8Max45	SCREW Dia. 8Max45	2
56	000 1101 06 4 3	RONDELLA Piana	RONDELLE	WASHER	6
57	000 1354 01 3 3	VITE T.E. Ø6Max14	VIS T.E. Ø6Max14	SCREW Dia. 6Max14	6
58	000 1111 06 6 3	RONDELLA Elastica	RONDELLE elastique	CLIP	6
59	000 1013 06 2 3	DADO	ECROU	NUT	6
60	136 19 630 0 00	TAMPONE	TAMPON	PAD	1

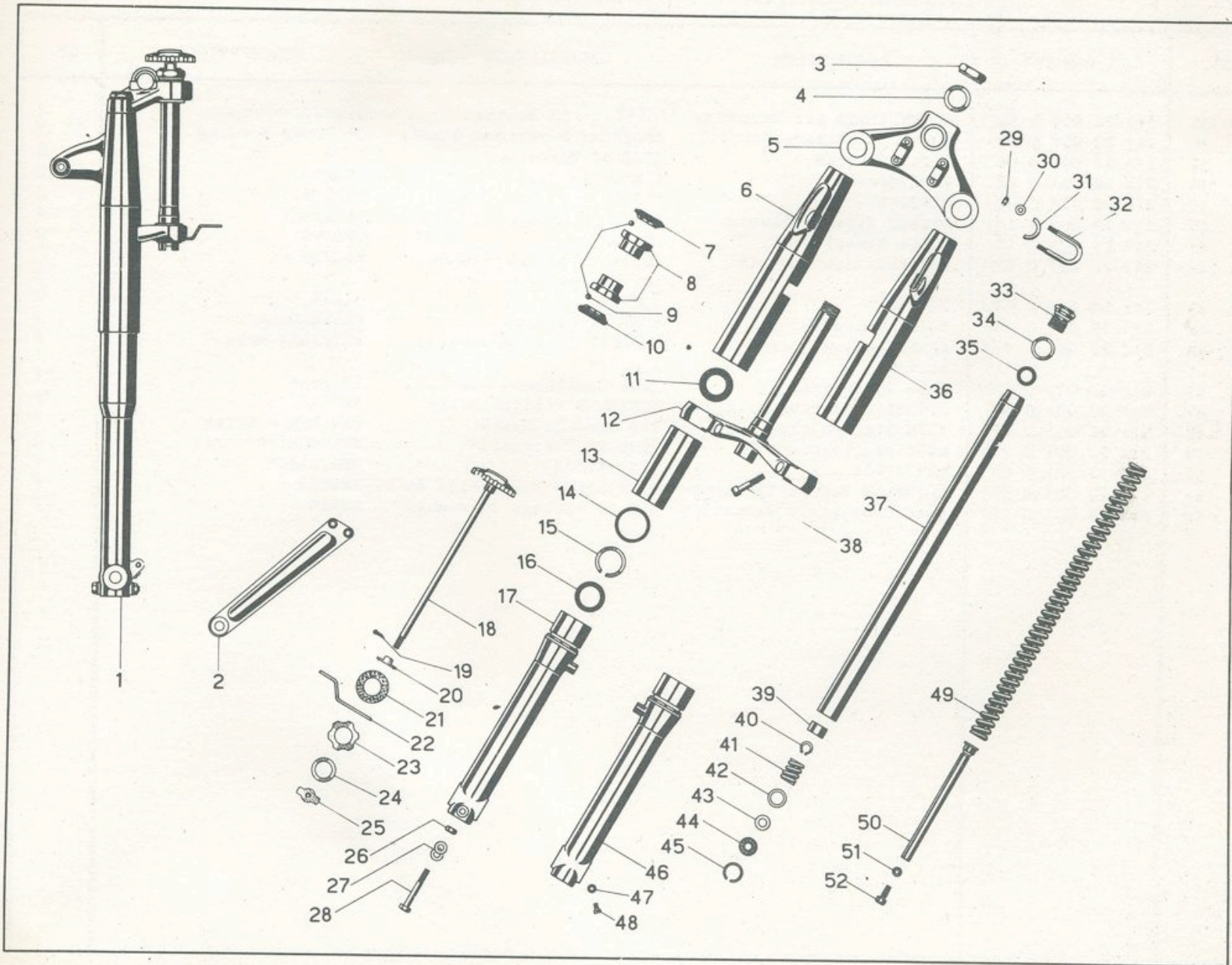

FIG.	ORD N°	DESCRIZIONE	DESCRIPTION	DESCRIPTION	QT.
1	211 22 001 0 80	FORCELLA Telescopica com.	FORUCHE Télésopique com.	TELESCOPIC Forck	1
2	211 24 006 0 80	FERMO Flangia	ARRÊT de la Bride	FLANGE Stop	1
3	211 22 001 0 36	DADO Centrale	ECROU Central	NUT	1
4	211 22 001 0 37	RONDELLA	RONDELLE	WASHER	1
5	211 22 001 0 27	TESTA Forcella	TÊTE de la Bride	FORK HEAD	1
6	211 22 001 0 22	FODERO Sup. Destro	FOURREAU Sup. Droit	RH Upper Housing	1
7	116 00 106 0 00	SEMICALOTTA Sup.	DEMI-Chapeau Superior	UPPER Half Sleeve	1
8	116 00 105 0 00	CALOTTA Sede Sfere	CHAPÊU Siège Billes	BALLS Seat	2
9	000 6397 05 1 0	SFERA 3/16"	BILLE 3/16"	BALL 3/16"	52
10	116 00 107 0 00	SEMICALOTTA Inferiore	DEMI Tasse Inferiore	LOWER Half Sleeve	1
11	211 22 001 0 24	ANELLO Elast.Fodero Sup.	CIRCLIP Fourreau Super.	RH Upper Ring	2
12	211 22 001 0 25	BASE Forcella	BASE de la Fourche	FORK Basement	1
13	211 22 001 0 21	FODERO Inferiore	FOURREAU Inferieur	LOWER Housing	2
14	211 22 001 0 20	GUARNIZIONE per Fodero In.	JOINT Pour Fourreau Infer.	GASKET	2
15	211 22 001 0 19	ANELLO Ritegno Guarniz.	BAGUE de Retien du Joint	RING	2
16	211 22 001 0 18	GUARNIZIONE Aste	JOINT des Tiges	GASKET	2
17	211 22 001 0 01	TUBO Scorrevole Destro	TUBE Coulissant Droit	RH Tube	1
18	211 22 001 0 38	POMOLO con Tirante	POMMEAU	STEERING Cont.Kinob	1
19	211 22 001 0 35	COPIGLIA	GOUPILLE	COTTER Pin	1
20	211 22 001 0 39	MOLLETTA Frenasterzo	RESSORT du Frein de Direct.	SPRING	1
21	211 22 001 0 31	RONDELLA Fibra Frenast.	RONDELLE en du Frein Direc.	FIBRE Washer	1
22	211 22 002 0 00	ELEMENTO Frenasterzo	ENSEMBLE du Frein de Direc.	STOP Plate	1
23	211 22 001 0 32	RONDELLA Elastica Frenast.	RONDELLE Elastique du Frein de Direction	CLIP	1
24	211 22 001 0 33	APPOGGIO Rondelle Elast.	APPUI de la Rondelle Elastique	WASHER Seat	1
25	211 22 001 0 34	RITEGNO Frenasterzo	RETIENT du Frein de Direc.	RETAINER	1
26	211 22 001 0 05	DADO	ECROU	WHELL Hinge	1
27	211 22 001 0 04	RONDELLA Piana	RONDELLE	WASHER	2
28	211 22 001 0 03	VITE Sarraggio	VIS de Serrage	SCREW	1
29	211 22 001 0 43	DADO	ECROU	UBOLT NUT	4
30	211 22 001 0 42	RONDELLA Piana	RONDELLE	WASHER	4
31	211 22 001 0 41	SEMIANELLO	DEMI-Bague	HALF- Ring	2
32	211 22 001 0 40	CAVALLOTTO	JONCTION	"U" BOLT	2
33	211 22 001 0 28	TAPPO Laterale	BOUCHON	PUG	2
34	211 22 001 0 29	RONDELLA per Tappo	RONDELLE du Bouchon	WASHER	2

FIG.	ORD. N°	DESCRIZIONE	DESCRIPTION	DESCRIPTION	QT.
35	211 22 001 0 30	GUARNIZIONE per Tappo	JOINT du Bouchon	GASKET	2
36	211 22 001 0 23	FODERO Superiore Sinistro	FOURREAU Superieur Gauche	LH Upper Housing	1
37	211 22 001 0 06	ASTA di Forza	TIGE de Force	TUBE	2
38	211 22 001 0 26	VITE Morsetto	VIS de la Tige	SCREW	2
39	211 22 001 0 09	PISTONE	PISTON	PISTON	2
40	211 22 001 0 10	ANELLO Ritegno Pistone	BAGUE de Retient du Piston	RETAINER	2
41	211 22 001 0 11	MOLLA Rimbalzo	RESSORT	SPRING	2
42	211 22 001 0 12	RONDELLA Spallamento	RONDELLE de Réglage de la soupape	WASHER	2
43	211 22 001 0 13	VALVOLA	SOUPAPE	VALVE	2
44	211 22 001 0 14	CORPO Valvole	CORP de Soupape	VALVE Body	2
45	211 22 001 0 15	ANELLO Ritegno corpo valvola	BAUGE de Retenue corp de soupape	RETAINER Ring	2
46	211 22 001 0 02	TUBO Scorrevole sin.	TUBE Coulissant Gauche	LH Tube	1
47	211 22 001 0 45	RONDELLA Scarico olio	RONDELLE Vidange huile	WASHER	2
48	211 22 001 0 44	VITE Scarico olio	VIS Vidange huile	OIL Drain Screw	2
49	211 22 001 0 07	MOLLA Molleggio	RESSORT Suspension	FEATHERING Screw	2
50	211 22 001 0 08	VARIATORE	REGULATEUR	REGULATOR	2
51	211 22 001 0 17	RONDELLA Tenuta variatore	RONDELLE d'Etanchéité du r.	WASHER	2
52	211 22 001 0 16	VITE Bloccaggio variatore	VIS De blocage du regul.	SCREW	2

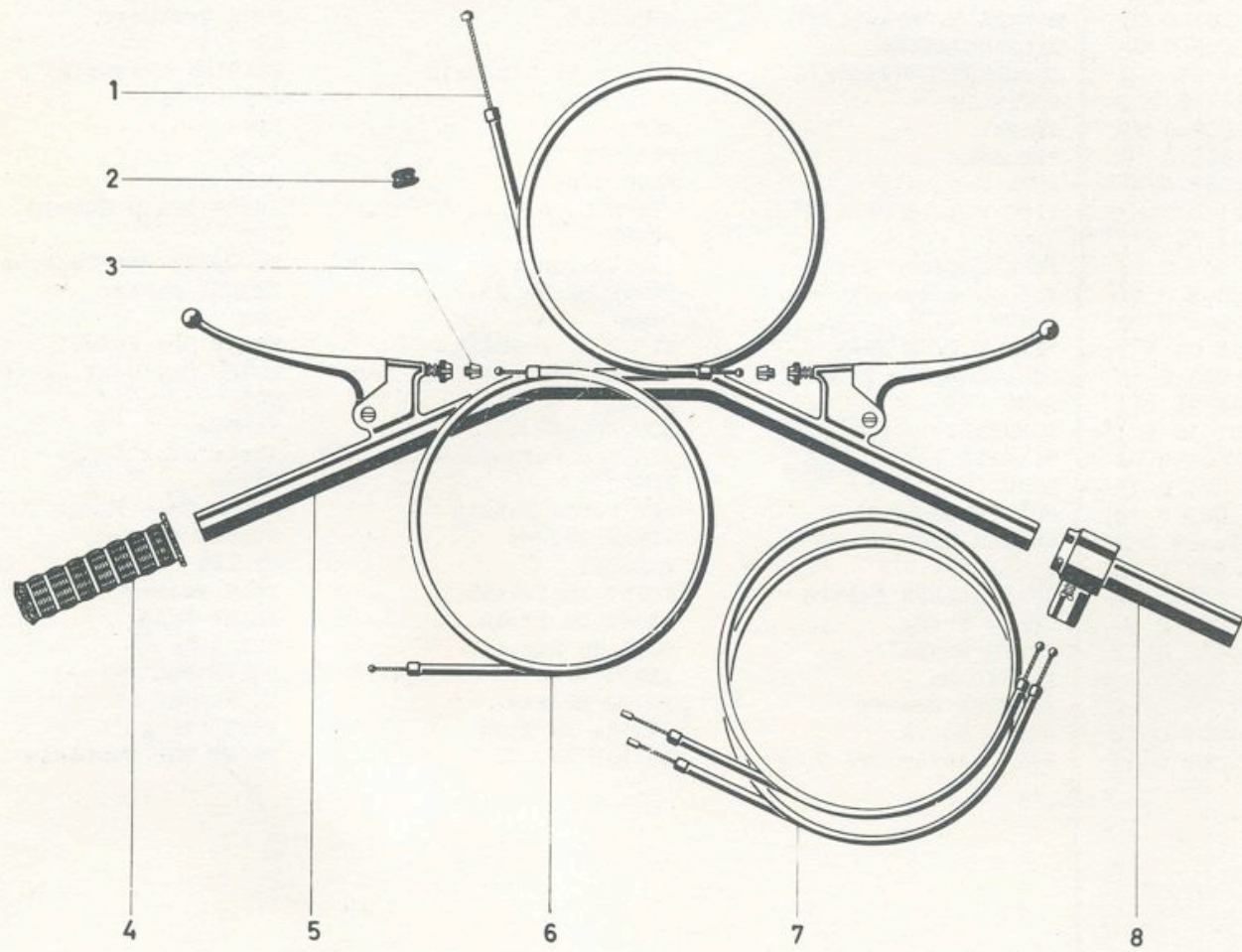

FIG.	ORD.N°	DESCRIZIONE	DESCRIPTION	DESCRIPTION	QT.
1	136 19 870 0 00	CAVO Freno	CABLE du Frein	BRAKE Cable	1
2	000 5401 01 0 0	PASSAFILO	PASSE-Cable	FAIRLEAD	1
3	211 23 008 0 00	FERMO Guaina	BLOCAGE de la Gaine	SHEATH Retainer	2
4	136 19 621 0 06	MANOPOLA Gomma	POIGNEE en Caoutchouc	RUBBER Grip	2
5	211 23 001 0 00	MANUBRIO	GUIDON	HANDLEBAR	1
6	211 23 005 0 00	CAVO Frizione	CABLE Embrayage	CLUTCH Cable	1
7	211 23 007 0 00	CAVO Gas	CABLE des Gaz	THROTTLE Cable	2
8	211 23 002 0 00	MANOPOLA Gas	POIGNEE Gaz	THROTTLE Grip	1

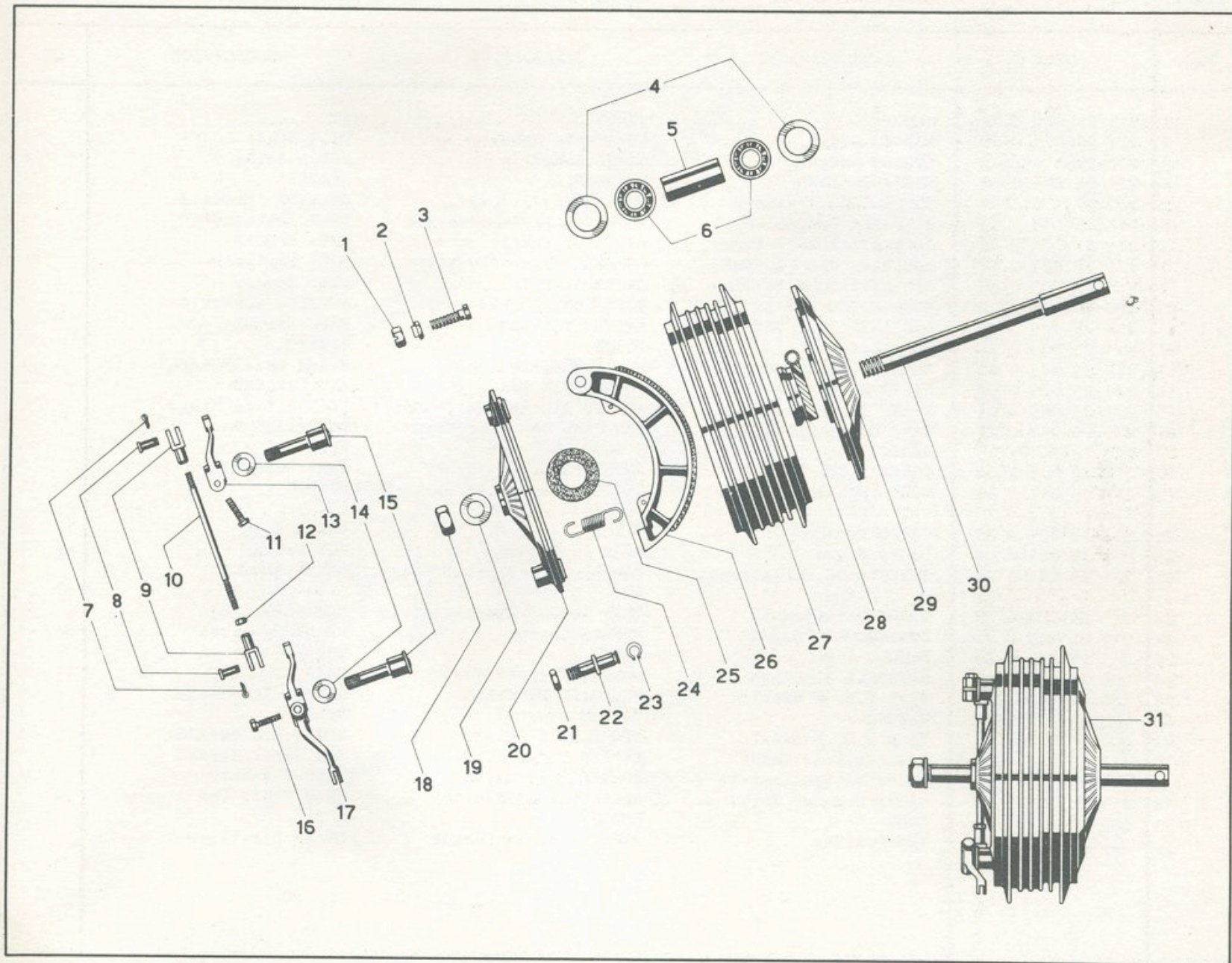



FIG.	ORD. N°	DESCRIZIONE	DESCRIPTION	DESCRIPTION	QT.
1	000 1019 10 2 3	DADO	ECROU	NUT	1
2	211 24 005 0 21	DADO Centraggio Asta	ECROU de Centrage de L'Axe	CENTERING Nut	1
3	211 24 005 0 22	PERNO Fermo Flangia	AXE Blocage de La Bride	FLANGE Stop Hinge	1
4	211 24 005 0 05	RONDELLA Parapolvere	RONDELLE	DUST Excluder	2
5	211 24 005 0 04	DISTANZIATORE	ENTRETOISE	SPACER	1
6	000 5734 01 1 2	CUSCINETTO 17x40x12	ROULEMENT 17x40x12	BEARING 17x40x12	2
7	000 1131 18 2 0	COPIGLIA	GOUPILLE	COTTER Pin	2
8	211 24 005 0 19	SPINA	AXE	PIN	2
9	211 24 005 0 18	FORCELLA	FOURCHE	FORK	2
10	211 24 005 0 17	ASTA Centrale	TIGE Central	ROD	1
11	000 1361 01 3 3	VITE T.E. Ø 6Max30	VIS T.E. Ø 6Max30	SCREW DIA Ø 6Max30	1
12	000 1011 06 2 6	DADO	ECROU	NUT	1
13	211 24 005 0 16	LEVA Comando Camma Sup.	LEVIER Commande Camme Sup.	LH Upper Cam Cont.Lever	1
14	211 24 005 0 11	RONDELLA Spallamento	RONDELLE de Réglege	THRUST Washer	2
15	211 24 005 0 10	CAMMA	CAME	CAM	2
16	000 1354 01 3 3	VITE T.E. Ø 6Max25	VIS T.E. Ø 6Max25	SCREW DIA 6Max25	1
17	211 24 005 0 15	LEVA Comando Camma Inf.	LEVIER Comande Came Inf.	LOWER Cam Cont.Lever	1
18	000 1014 16 2 3	DADO	ECROU	NUT	1
19	000 1101 16 4 3	RONDELLA	RONDELLE	WASHER	1
20	211 24 005 0 06	FLANGIA Porta Ceppi	PLATEAU Porte Sabots	BRAKE Shoe Lange	1
21	211 24 005 0 13	DADO	ECROU	NUT	2
22	211 24 005 0 12	FULCRO Ceppi	AXE Porte Sabots	BRAKE Shoe Hinge	2
23	000 5064 09 0 0	ANELLO Seeger	ANEAU Seeger	SEEGER Ring	2
24	211 24 005 0 09	MOLLA	RESSORT	SPRING	2
25	211 24 005 0 07	GUARNIZIONE Feltro	JOINT en Feutre	FELT Washer	1
26	211 24 005 0 08	CEPPO Freno	SABOT Du Frein	BRAKE Shoe	2
27	211 24 005 0 01	CORPO Mozzo	CORP du Moyeau	HUB Body	1
28	211 26 023 0 00	RINVIO Km	RENVOL	DRIVE Pad	1
29	211 24 005 0 02	FLANGIA Destra	BRIDE Droite	RH FLANGE	1
30	211 24 005 0 14	PERNO Ruota	AXE de La Roue	WHEEL Ginge	1
31	211 24 005 0 80	MOZZO Anteriore Comp.	MOYEAU Av. Complet	FRONT Hub Complete	1

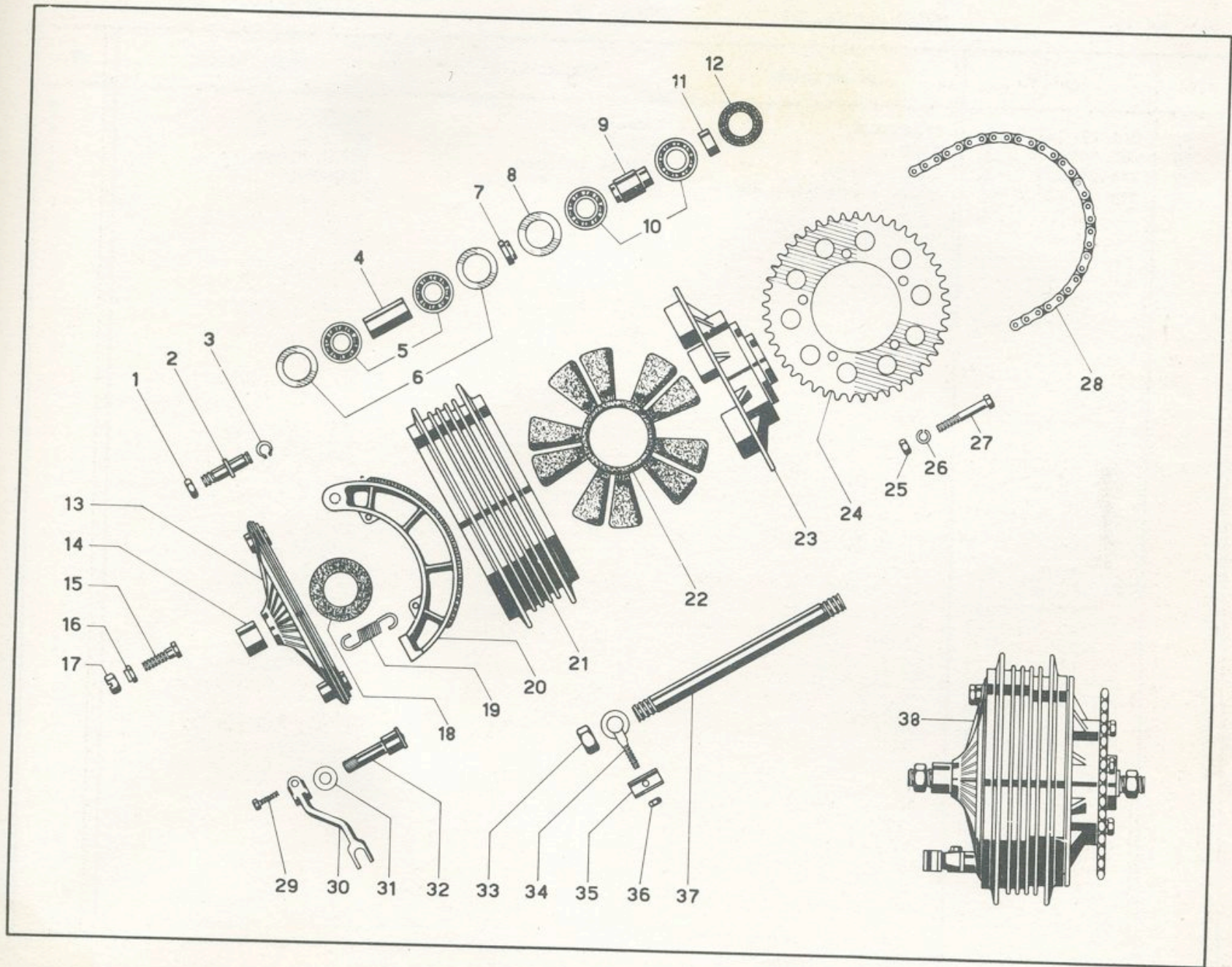

FIG.	ORD. N.	DESCRIZIONE	DESCRIPTION	DESCRIPTION	QT.
1	211 25 005 0 11	DADO	ECROU	NUT	2
2	211 25 005 0 10	FULCRO Ceppi	AXE Porte Sabots	SHOE Hinge	2
3	000 5064 09 0 0	ANELLO Seeger	BAGUE Seeger	SEEGER Ring	2
4	211 25 005 0 14	DISTANZIATORE	ENTRETOISE	SPACER	1
5	000 5734 01 1 2	CUSCINETTO 17x40x12	ROULEMENT 17x40x12	BEARING 17x40x12	2
6	211 25 005 0 13	RONDELLA Parapolvere	RONDELLE Pare-Poussiere	DUST Excluder	1
7	211 25 005 0 16	DISTANZIATORE Esterno	ENTRETOISE Ext.	EXT. SPACER	1
8	211 25 005 0 17	RONDELLA PARAPOLVERE	RONDELLE Pare Poussiere	DUST Excluder	1
9	211 25 005 0 18	DISTANZIATORE Interno	ENTRETOISE Int.	INT. Spacer	1
10	000 5693 01 1 2	CUSCINETTO 20x42x12	ROULEMENT 20x42x12	BEARING 20x42x12	2
11	211 25 005 0 19	DISTANZIATORE Esterno	ENTRETOISE Ext.	EXT. SPACER	1
12	211 25 005 0 20	GUARNIZIONE	JOINT	GASKET	1
13	211 25 005 0 03	PLANGIA Porta Ceppi	PLATEAU Porte Sabots	BAAKE Shoe Flange	1
14	211 25 005 0 02	DISTANZIATORE Esterno	ENTRETOISE Ext.	EXT. SPACER	1
15	211 25 005 0 24	PERNO Fermo Plangia	AXE de Blocage de la Bride	FLANGE Stop Hinge	1
16	211 25 005 0 25	DADO Centraggio Asta	ECROU de Centrage	CENTERING Nut	1
17	000 1019 10 2 3	DADO	ECROU	NUT	1
18	211 25 005 0 04	GUARNIZIONE Feltro	JOINT Feutre	FELT Gasket	1
19	211 25 005 0 06	MOLLA Richiamo Ceppi	RESSORT de Rappel des Sabots	SPRING	1
20	211 25 005 0 05	CEPPO Freno	SABOT	BRAKE Shoe	2
21	211 25 005 0 01	CORPO Mozzo	CORP du Moyeau	HUB Body	1
22	211 25 005 0 21	SILENTBLOC Parastrappi	TAMPON Accouplement Elasti que	SILENTBLOCK	1
23	211 25 005 0 15	CORPO Parastrappi	CORP Accouplement Elastique	FLEX Coupling	1
24	211 25 005 0 22	INGRANAGGIO Catena	PIGNON Chaine	CHAIN Sprocket	1
25	211 25 005 0 23	DADO	ECROU	NUT	5
26	000 1111 08 6 3	RONDELLA Elastica	RONDELLE Elastique	CLIP	5
27	000 1463 01 3 3	VITE T.E. Ø 8Max55	VIS T.E. Ø 8Max55	SCREW DIA 8Max55	5
28	000 4500 19 0 0	CATENA	CHAINE	CHAIN	1
29	000 1357 01 3 3	VITE T.E. Ø 6Max20	VIS T.E. Ø 6Max20	SCREW DIA 6Max20	1
30	211 25 005 0 09	LEVA Comando Camme	LEVIER Commande Came	CAM Cont. Lever	1
31	211 25 005 0 08	RONDELLA Spallamento	RONDELLE de Réglage	THRUST Washer	1
32	211 25 005 0 07	CAMMA Comando Ceppi	CAME Comande Sabots	SHOE Cont. Cam	1
33	000 1014 16 2 3	DADO	ECROU	NUT	2
34	146 41 394 0 00	TENDICATENA	TENDEUR de la Chaine	CHAIN Stretcher	2

FIG.	ORD.N.	DESCRIZIONE	DESCRIPTION	DESCRIPTION	QT.
35	211 25 007 0 00	PIASTRINA	PLAQUETTE	PLATE	2
36	000 1013 06 2 3	DADO	ECROU	NUT	4
37	211 25 005 0 12	PERNO Ruota	AXE de la Roue	WHEEL Hinge	1
38	211 25 005 0 80	MOZZO Posteriore Comp.	MOYEAU Ar. Complet	REAR Hub	1

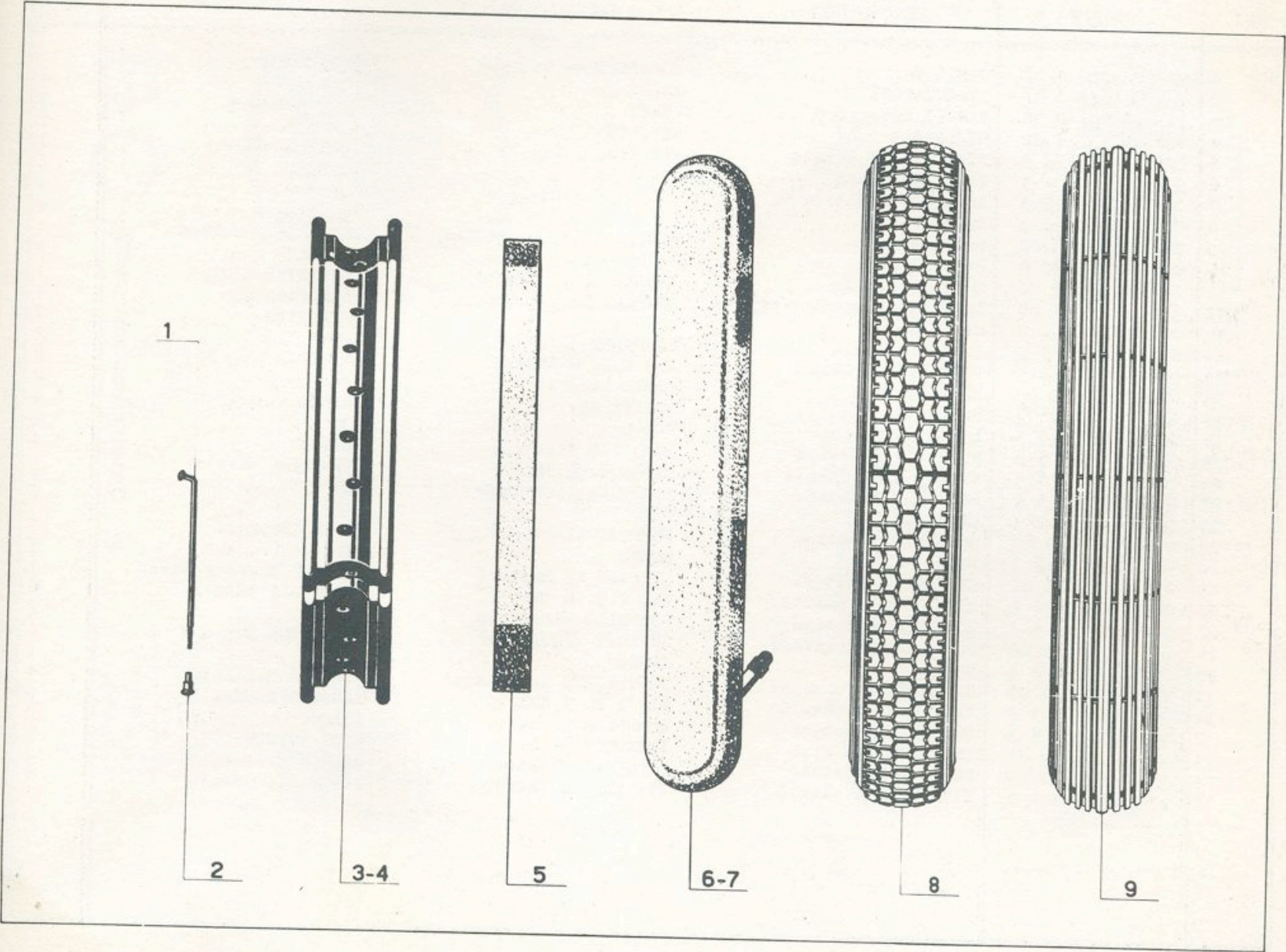

FIG.	ORD. N.	DESCRIZIONE	DESCRIPTION	DESCRIPTION	QT.
1	211 24 002 0 00	RAGGIO 3x120	RAYON 3x120	SPOKE 3x120	72
2	136 19 723 0 00	NIFLO	ECROU de Rayon	NIPLES	72
3	136 19 692 0 00	CERCHIO 1,6x18" AS Ant.	JANTE 1,6x18"AS AV.	FRONT Rim 1,6x18"	1
4	211 25 002 0 00	CERCHIO 1,85x18" AS Post.	JANTE 1,85x18" AS AR.	REAR Rim 1,85x18"	1
5	136 19 725 0 00	FASCIA Protezione	COLLIER de Protection	PROTECTION	2
6	136 19 726 0 00	CAMERA D'Aria 2,75x18"Ant.	CHAMBRE à air 2,25x18"AV.	FRONT Tube 2,75x18"	1
7	211 25 010 0 00	CAMERA D'Aria 3,25x18"Post.	CHAMBRE à air 3,25x18"AR.	REAR Tube 3,25x18"	1
8	211 25 011 0 00	COPERTURA Scolpita 3,25x18"	COUVERTURE Sculptée 3,25x18"	TYRE 3,25x18"	1
9	136 19 727 1 00	COPERTURA Rigata 2,75x18" Rinforz.	COUVERTURE Rayée 2,75x18" Renforcée	TYRE 2,75x18"	1

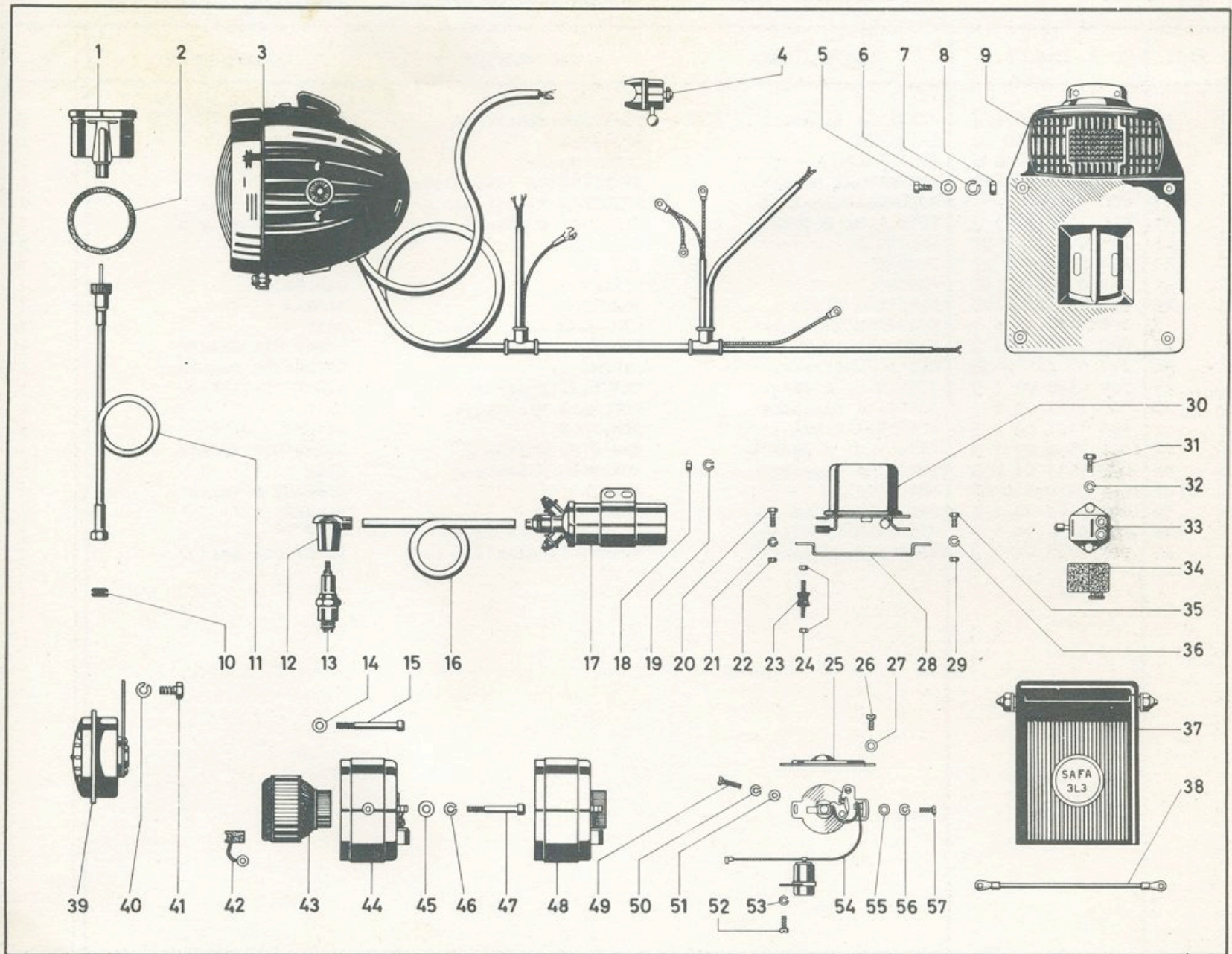

FIG.	ORD.N.	DESCRIZIONE	DESCRIPTION	DESCRIPTION	QT.
1	211 26 022 0 00	CONTA Km.	COMPTEUR de Vitesse	TACHOMETER	1
2	211 26 022 0 01	GUARNIZIONE Or	JOINT Or	"O" Ring	1
3	211 26 001 0 00	FANALE Anteriore	PHARE	FRONT Headlamp	1
4	136 19 635 0 02	DEVIATORE Luce	DEVIATEUR Code	SELECTOR	1
5	000 1354 01 3 3	VITE T.E. $\phi$ 6Max14	VIS T.E. $\phi$ 6Max14	SCREW DIA 6Max14	4
6	000 1101 06 4 3	RONDELLA Piana	RONDELLE	WASHER	4
7	000 1111 06 6 3	RONDELLA Elastica	RONDELLE Elastique	CLIP	4
8	000 1013 06 2 3	DADO	ECROU	NUT	4
9	211 26 002 0 00	PORTATARGA	PORTE Plaque de Police	NUMBERPLATE Holder	1
10	000 5404 00 0 0	PASSAFILO	PASSE Cable	FAIRLEAD	2
11	211 26 024 0 00	CORDA Conta Km	CABLE Tachymètre	TACHOMETER Cable	1
12	154 59 100 1 00	CAPPUCCIO Candela	CHAPEAU Bougie	SPARK Plug Cap	2
13	000 4507 09 0 0	CANDELA	BOUGIE	SPARK Plug	2
14	000 1101 06 4 3	RONDELLA Piana	RONDELLE	WASHER	2
15	000 2167 01 3 3	VITE E.I. $\phi$ 6Max70	VIS E.I. $\phi$ 6Max70	SCREW DIA 6Max70	2
16	172 84 113 0 00	FILO Candela	CABLE Bougie	WIRE	2
17	211 26 010 0 00	BOBINA AT	BOBINE HT.	AC COIL	2
18	000 1011 05 2 3	DADO	ECROU	NUT	4
19	000 1111 05 6 3	RONDELLA Elastica	RONDELLE Elastique	CLIP	4
20	000 1304 01 1 3	VITE T.E. $\phi$ 5Max14	VIS T.E. $\phi$ 5Max14	SCREW DIA 5Max14	1
21	000 1111 05 6 3	RONDELLA Elastica	RONDELLE Elastique	CLIP	1
22	000 1011 04 2 3	DADO	ECROU	NUT	1
23	211 26 017 0 00	SUPPORTO Elastico	SUPPORT Elastique	RUBBER Support	3
24	000 1011 04 2 3	DADO	ECROU	NUT	3
25	211 02 015 0 00	COPERCHIO Ruttore	CHAPEAU du Rupteur	CONTACT Breaker Cover	1
26	000 2705 01 1 3	VITE T.C. $\phi$ 5Max12	VIS T.C. $\phi$ 5Max12	SCREW DIA 5Max12	2
27	000 1111 05 6 3	RONDELLA Elastica	RONDELLE Elastique	CLIP	2
28	211 26 016 0 00	SUPPORTO Regolatore	SUPPORT Régulateur	REGULATOR Support	1
29	000 1011 04 2 3	DADO	ECROU	NUT	1
30	211 26 015 0 00	REGOLATORE Tensione	REGULATEUR de Tension	VOLTAGE Regulator	1
31	000 1302 01 1 3	VITE T.E. $\phi$ 5Max10	VIS T.E. $\phi$ 5Max10	SCREW DIA 5Max10	2
32	000 1111 05 6 3	RONDELLA Elastica	RONDELLE Elastique	CLIP	2
33	172 84 717 0 00	INTERUTTORE Stop	INTERUPTEUR Stop	STOP SWITCH	1
34	136 19 710 0 00	PROTEZIONE Interr.	PROTECTION Interrupteur	SWITCH Protection	1
35	000 1302 01 1 3	VITE T.E. $\phi$ 5Max10	VIS T.E. $\phi$ 5Max10	SCREW DIA 5Max10	1



FIG.	ORD. N.	DESCRIZIONE	DESCRIPTION	DESCRIPTION	QT.
36	000 1111 05 6 3	RONDELLA Elastica	RONDELLE Elastique	CLIP	1
37	157 64 460 0 00	BATTERIA	BATTERIE	BATTERY	1
38	000 5530 00 0 0	CAVO Massa	CABLE Masse	GROUND CABLE	1
39	172 84 716 0 00	AVVISATORE Acustico	AVERTISSEUR Acoustique	HORN	1
40	000 1111 08 6 3	RONDELLA Elastica	RONDELLE Elastique	CLIP	1
41	000 1452 02 3 3	VITE T.E. $\varnothing$ 8Max16	VIS T.E. $\varnothing$ 8Max16	SCREW DIA 8Max16	1
42	211 03 021 0 01	SPAZZOLE	CHARBONS	BRUSHES	2
43	211 03 021 0 02	ROTORE	ROTOR	ROTOR	1
44	211 03 021 0 00	DINAMO	DYNAMO	GENERATOR	1
45	211 03 022 0 00	RONDELLA Piana	RONDELLE	WASHER	1
46	000 1111 06 6 3	RONDELLA Elastica	RONDELLE Elastique	CLIP	1
47	000 2163 01 3 3	VITE E.I. $\varnothing$ 6Max50	VIS E.I. $\varnothing$ 6Max50	SCREW DIA 6Max50	1
48	211 03 021 0 80	DINAMO Composta	DYNAMO	GENERATOR Complete	1
49	000 2659 01 1 3	VITE T.C. $\varnothing$ 4Max20	VIS T.C. $\varnothing$ 4Max20	SCREW DIA 4Max20	1
50	000 1111 04 6 3	RONDELLA Elastica	RONDELLE Elastique	CLIP	1
51	000 1101 04 4 3	RONDELLA Piana	RONDELLE	WASHER	1
52	000 2656 01 1 3	VITE T.C. $\varnothing$ 4Max12	VIS T.C. $\varnothing$ 4Max12	SCREW DIA 4Max12	1
53	000 1111 04 6 3	RONDELLA Elastica	RONDELLE Elastique	CLIP	1
54	211 04 035 0 00	RUTTORE	RUPTEUR	CONTACT Breaker	1
55	000 1101 04 4 3	RONDELLA Piana	RONDELLE	WASHER	2
56	000 1111 04 6 3	RONDELLA Elastica	RONDELLE Elastique	CLIP	2
57	000 2656 01 1 3	VITE T.C. $\varnothing$ 4Max12	VIS T.C. $\varnothing$ 4Max12	SCREW DIA 4Max12	2

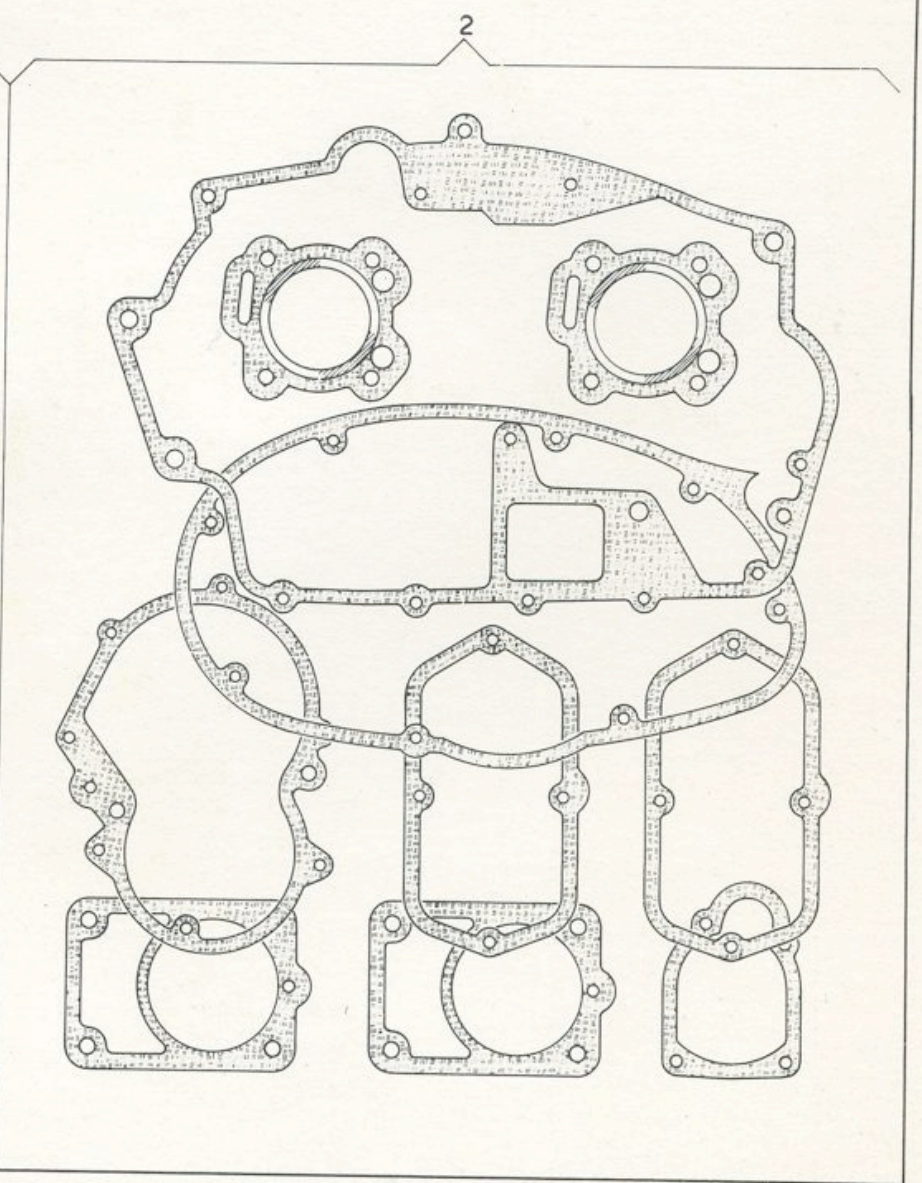
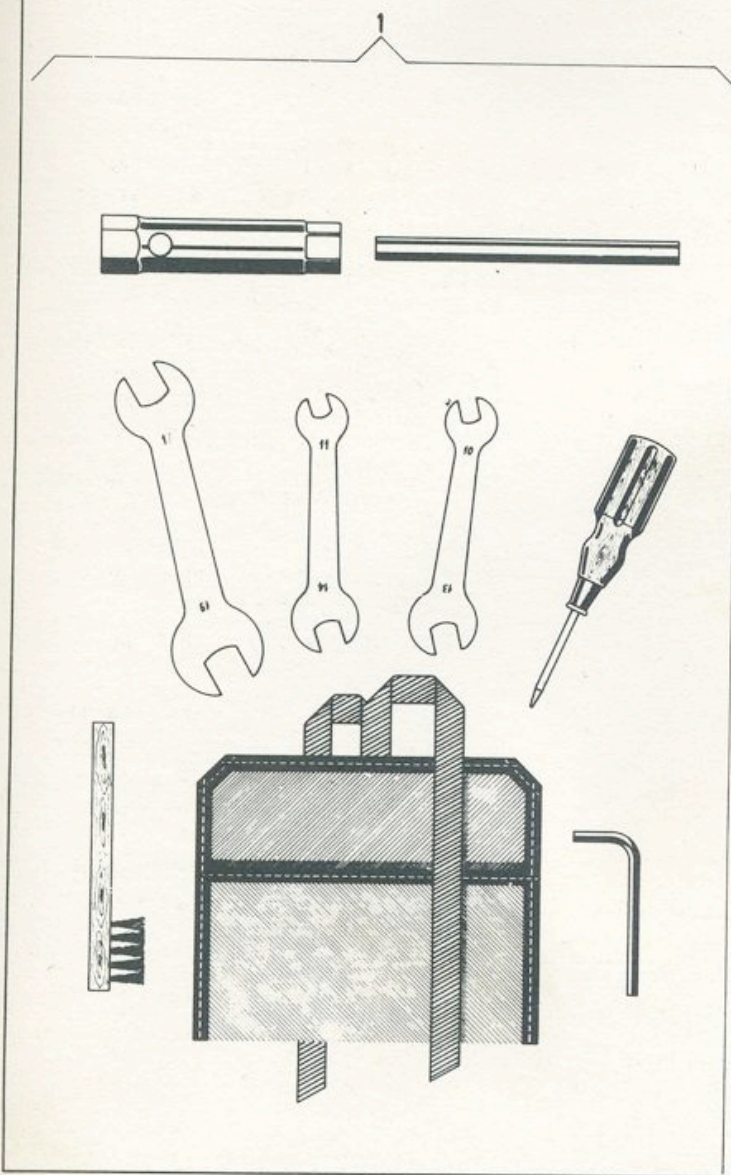

FIG.	ORD. N°	DESCRIZIONE	DESCRIPTION	DESCRIPTION	QT.
1	211 27 000 0 80	SERIE ATTREZZI: BORSA CHIAVE Fissa 17/18 CHIAVE Fissa 10/13 CHIAVE Fissa 11/14 CHIAVE Esagonale 5 CHIAVE a tubo 21/24 MANICO CACCIAVITE SPAZZOLINO	OUTILS EN DOTATION: TROUSSE a outils CLEF 17/18 CLEF 10/13 CLEF 11/14 CLEF Hexagonal 5 CLEF à tube 21/24 MANCHE TOURNEVIS BROSSE	TOOLS SET : TOOLS Bag SPANNER 17/18 SPANNER 10/13 SPANNER 11/14 HEXAGONAL Spanner 5 TUBE Spanner 21/24 HANDLE SCREW-Driver BRUSH	
2	211 02 040 0 80	SERIE GUARNIZIONI CARTER COPERCHIO Frizione COPERCHIO Ingranaggi cammes COPERCHIO Selettore TRA cil. e carter  TRA Cil. e testa  FRA Testa e Cappello	SERIE DE JOINTS: CARTER COUVERCLE Embrayage COUVERCLE Pignon cames  COUVERCLE Sélecteur ENTRE carter e cylindre  ENTRE Cylindre et Culasse  ENTRE Culasse et chapeau	SET OF GASKET: CRANCKASE CLUTCH Cover CAMES Gear cover  SPEED Change Cover BETWEEN cylinder and cranckase BETWEEN Cylinder and cylinder head BETWEEN Cylinder head and cover	